



SERVICE YOU CAN TRUST

| | | |
|---|-------------------------------|--------------------------------|
| Double Width Tower 1.8m Long x 1.45m Wide | Working Height 3.2m | Platform Height 1.2m |
|---|-------------------------------|--------------------------------|

Tower Components

| Item | Description | Quantity |
|------|---|----------|
| 1 | 150mm Locking Caster | 4 |
| 2 | Adjustable Leg 500mm | 4 |
| 3 | 1m 4 Rung Frame | 0 |
| 4 | 1.5m 6 Rung Frame | 0 |
| 5 | 2m 8 Rung Frame | 2 |
| 6 | 1.8m Trapdoor Platform | 1 |
| 7 | 1.8m Fixed Platform | 1 |
| 8 | 1.8m Horizontal Brace | 6 |
| 9 | 2.1m Diagonal Brace | 2 |
| 10 | Complete Toe Board Set | 1 |
| 11 | S1 Stabiliser | 0 |
| 12 | S2 Stabiliser | 0 |
| 13 | Instruction Manual & EN1004:-1:2020 certificate of conformity | 1 |

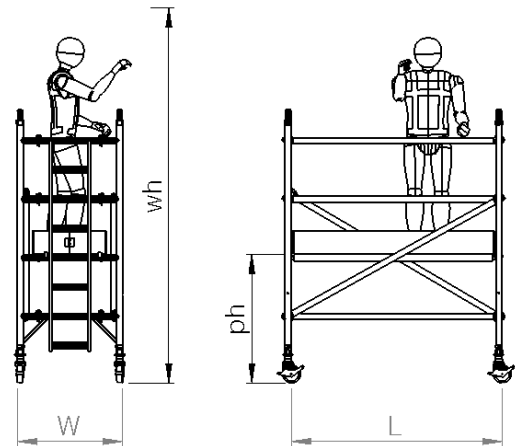
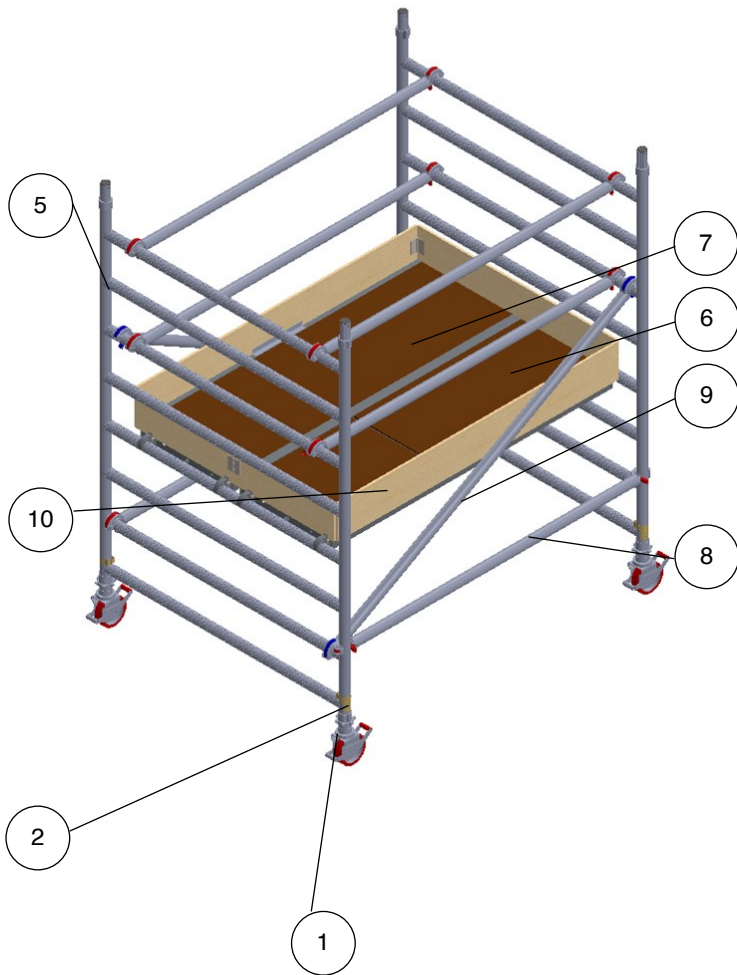

Technical information:

| | |
|---|--------------------|
| Base Dimensions: | (L)1.8m X (W)1.45m |
| Maximum Platform Height (ph): | 1.2m |
| Maximum Working Height (wh): | 3.2m |
| Maximum Working Load Per Platform: | 275kg |
| Maximum Working Load Per Tower: (including tower weight) | 950kg |
| Weight: | 85kg |

Mr Plant Hire
120 Hertford Road Enfield
London EN3 5AX

☎ 020 8351 3434
✉ info@mrplanthire.co.uk

BS 8620:2016
TM1005
testandresearch.org



SERVICE YOU CAN TRUST

| | | |
|---|-------------------------------|--------------------------------|
| Double Width Tower 1.8m Long x 1.45m Wide | Working Height 3.7m | Platform Height 1.7m |
|---|-------------------------------|--------------------------------|

Tower Components

| Item | Description | Quantity |
|------|---|----------|
| 1 | 150mm Locking Caster | 4 |
| 2 | Adjustable Leg 500mm | 4 |
| 3 | 1m 4 Rung Frame | 2 |
| 4 | 1.5m 6 Rung Frame | 2 |
| 5 | 2m 8 Rung Frame | 0 |
| 6 | 1.8m Trapdoor Platform | 1 |
| 7 | 1.8m Fixed Platform | 1 |
| 8 | 1.8m Horizontal Brace | 6 |
| 9 | 2.1m Diagonal Brace | 3 |
| 10 | Complete Toe Board Set | 1 |
| 11 | S1 Stabiliser | 0 |
| 12 | S2 Stabiliser | 0 |
| 13 | Instruction Manual & EN1004:-1:2020 certificate of conformity | 1 |

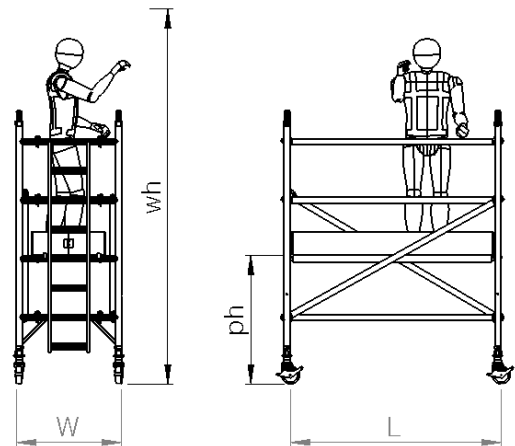
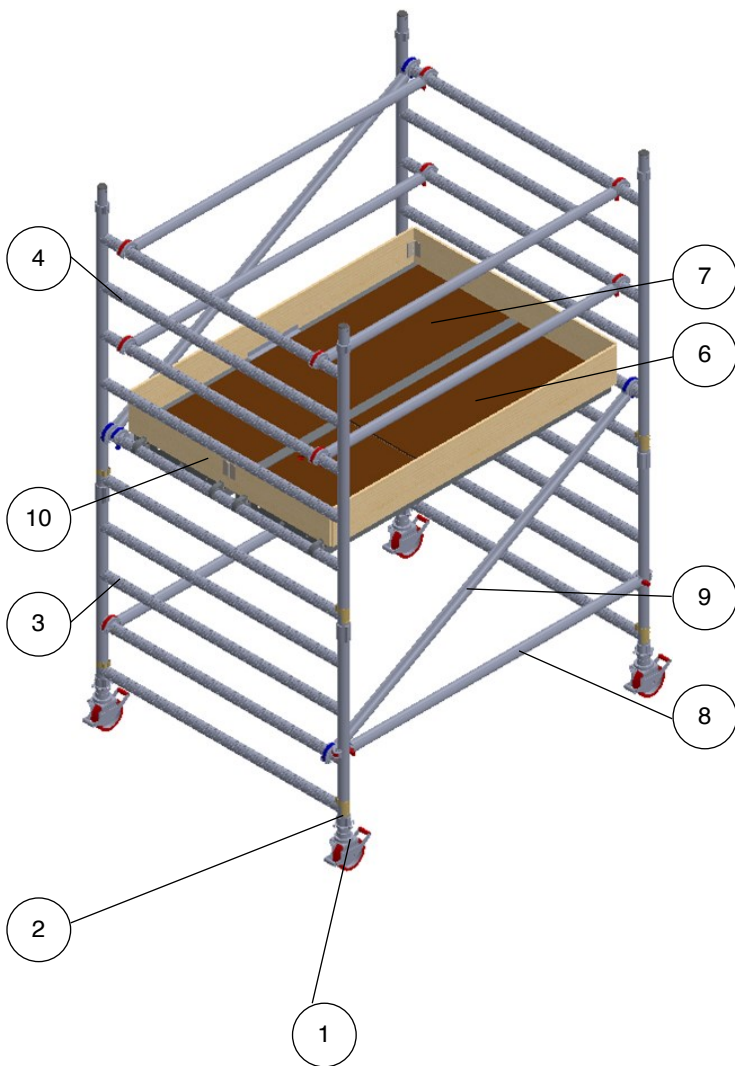

Technical information:

| | |
|---|--------------------|
| Base Dimensions: | (L)1.8m X (W)1.45m |
| Maximum Platform Height (ph): | 1.7m |
| Maximum Working Height (wh): | 3.7m |
| Maximum Working Load Per Platform: | 275kg |
| Maximum Working Load Per Tower: (including tower weight) | 950kg |
| Weight: | 92.7kg |

Mr Plant Hire
120 Hertford Road Enfield
London EN3 5AX

☎ 020 8351 3434
✉ info@mrplanthire.co.uk

BS 8620:2016
TM1005
testandresearch.org



SERVICE YOU CAN TRUST

| | | |
|---|-------------------------------|--------------------------------|
| Double Width Tower 1.8m Long x 1.45m Wide | Working Height 4.2m | Platform Height 2.2m |
|---|-------------------------------|--------------------------------|

Tower Components

| Item | Description | Quantity |
|------|---|----------|
| 1 | 150mm Locking Caster | 4 |
| 2 | Adjustable Leg 500mm | 4 |
| 3 | 1m 4 Rung Frame | 2 |
| 4 | 1.5m 6 Rung Frame | 0 |
| 5 | 2m 8 Rung Frame | 2 |
| 6 | 1.8m Trapdoor Platform | 1 |
| 7 | 1.8m Fixed Platform | 1 |
| 8 | 1.8m Horizontal Brace | 6 |
| 9 | 2.1m Diagonal Brace | 3 |
| 10 | Complete Toe Board Set | 1 |
| 11 | S1 Stabiliser | 4 |
| 12 | S2 Stabiliser | 0 |
| 13 | Instruction Manual & EN1004:-1:2020 certificate of conformity | 1 |

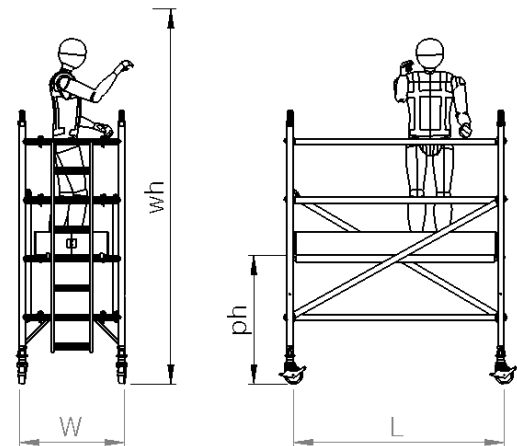
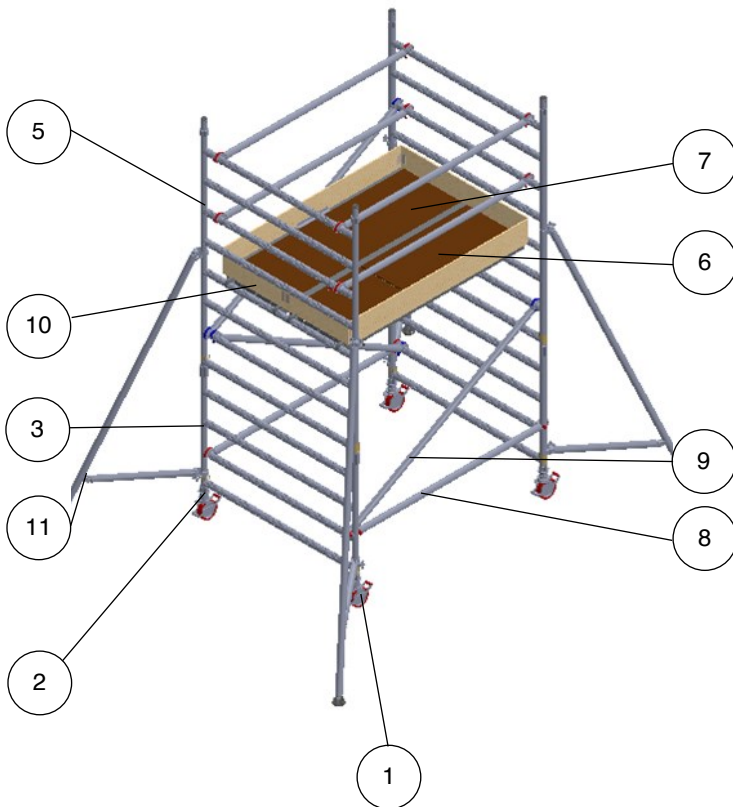

Technical information:

| | |
|---|--------------------|
| Base Dimensions: | (L)1.8m X (W)1.45m |
| Maximum Platform Height (ph): | 2.2m |
| Maximum Working Height (wh): | 4.2m |
| Maximum Working Load Per Platform: | 275kg |
| Maximum Working Load Per Tower: (including tower weight) | 950kg |
| Weight: | 113kg |

Mr Plant Hire
120 Hertford Road Enfield
London EN3 5AX

☎ 020 8351 3434
✉ info@mrplanthire.co.uk





SERVICE YOU CAN TRUST

| | | |
|---|-------------------------------|--------------------------------|
| Double Width Tower 1.8m Long x 1.45m Wide | Working Height 4.7m | Platform Height 2.7m |
|---|-------------------------------|--------------------------------|

Tower Components

| Item | Description | Quantity |
|------|---|----------|
| 1 | 150mm Locking Caster | 4 |
| 2 | Adjustable Leg 500mm | 4 |
| 3 | 1m 4 Rung Frame | 0 |
| 4 | 1.5m 6 Rung Frame | 2 |
| 5 | 2m 8 Rung Frame | 2 |
| 6 | 1.8m Trapdoor Platform | 1 |
| 7 | 1.8m Fixed Platform | 1 |
| 8 | 1.8m Horizontal Brace | 6 |
| 9 | 2.1m Diagonal Brace | 4 |
| 10 | Complete Toe Board Set | 1 |
| 11 | S1 Stabiliser | 4 |
| 12 | S2 Stabiliser | 0 |
| 13 | Instruction Manual & EN1004:-1:2020 certificate of conformity | 1 |

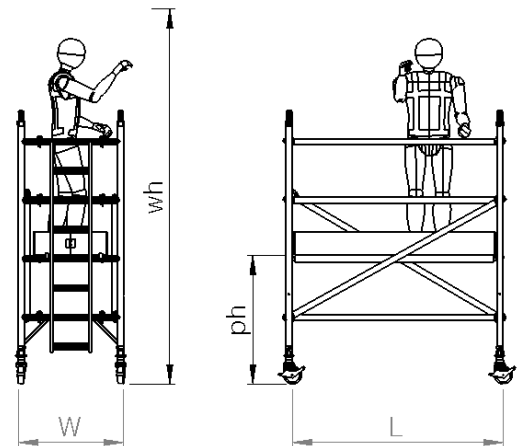
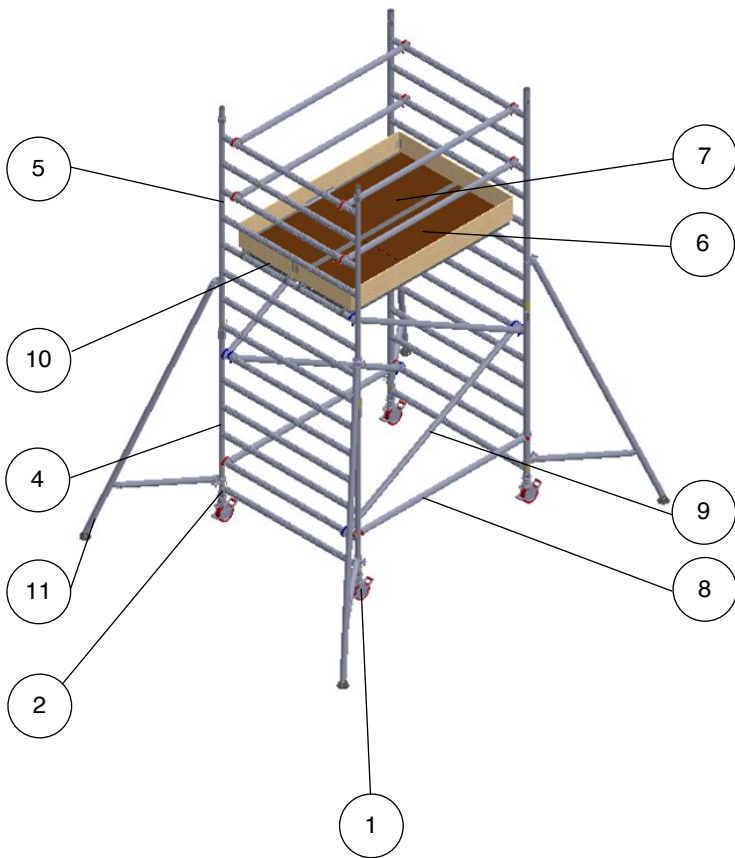

Technical information:

| | |
|---|--------------------|
| Base Dimensions: | (L)1.8m X (W)1.45m |
| Maximum Platform Height (ph): | 2.7m |
| Maximum Working Height (wh): | 4.7m |
| Maximum Working Load Per Platform: | 275kg |
| Maximum Working Load Per Tower: (including tower weight) | 950kg |
| Weight: | 119.4kg |

Mr Plant Hire
120 Hertford Road Enfield
London EN3 5AX

☎ 020 8351 3434
✉ info@mrplanthire.co.uk



| | | |
|---|-------------------------------|--------------------------------|
| Double Width Tower 1.8m Long x 1.45m Wide | Working Height 5.2m | Platform Height 3.2m |
|---|-------------------------------|--------------------------------|

Tower Components

| Item | Description | Quantity |
|------|---|----------|
| 1 | 150mm Locking Caster | 4 |
| 2 | Adjustable Leg 500mm | 4 |
| 3 | 1m 4 Rung Frame | 0 |
| 4 | 1.5m 6 Rung Frame | 0 |
| 5 | 2m 8 Rung Frame | 4 |
| 6 | 1.8m Trapdoor Platform | 2 |
| 7 | 1.8m Fixed Platform | 1 |
| 8 | 1.8m Horizontal Brace | 10 |
| 9 | 2.1m Diagonal Brace | 5 |
| 10 | Complete Toe Board Set | 1 |
| 11 | S1 Stabiliser | 4 |
| 12 | S2 Stabiliser | 0 |
| 13 | Instruction Manual & EN1004:-1:2020 certificate of conformity | 1 |

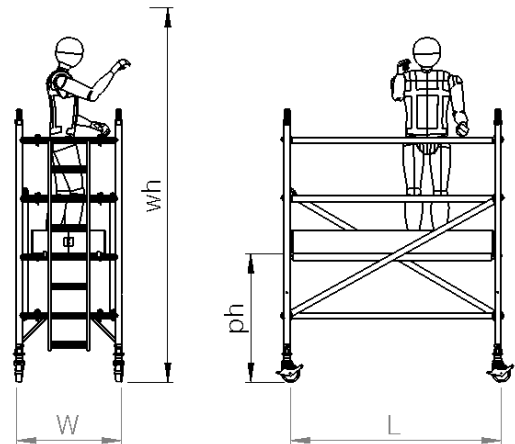
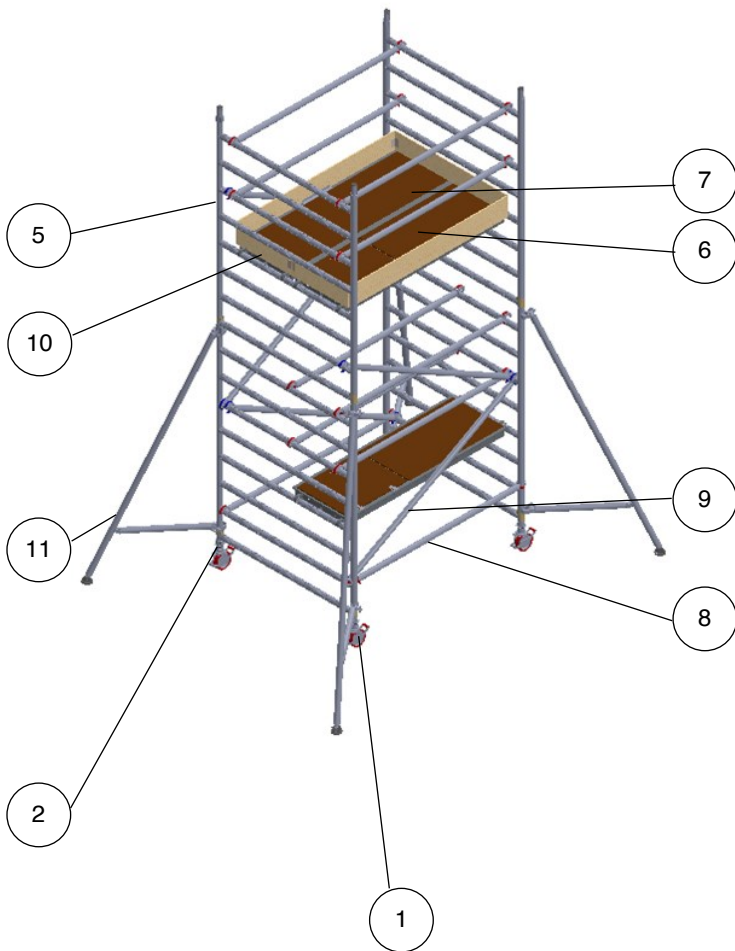

Technical information:

| | |
|---|--------------------|
| Base Dimensions: | (L)1.8m X (W)1.45m |
| Maximum Platform Height (ph): | 3.2m |
| Maximum Working Height (wh): | 5.2m |
| Maximum Working Load Per Platform: | 275kg |
| Maximum Working Load Per Tower: (including tower weight) | 950kg |
| Weight: | 146.6kg |

| | | |
|---|-------------------------------|--------------------------------|
| Double Width Tower 1.8m Long x 1.45m Wide | Working Height 5.7m | Platform Height 3.7m |
|---|-------------------------------|--------------------------------|

Tower Components

| Item | Description | Quantity |
|------|---|----------|
| 1 | 150mm Locking Caster | 4 |
| 2 | Adjustable Leg 500mm | 4 |
| 3 | 1m 4 Rung Frame | 2 |
| 4 | 1.5m 6 Rung Frame | 2 |
| 5 | 2m 8 Rung Frame | 2 |
| 6 | 1.8m Trapdoor Platform | 2 |
| 7 | 1.8m Fixed Platform | 1 |
| 8 | 1.8m Horizontal Brace | 10 |
| 9 | 2.1m Diagonal Brace | 6 |
| 10 | Complete Toe Board Set | 1 |
| 11 | S1 Stabiliser | 4 |
| 12 | S2 Stabiliser | 0 |
| 13 | Instruction Manual & EN1004:-1:2020 certificate of conformity | 1 |

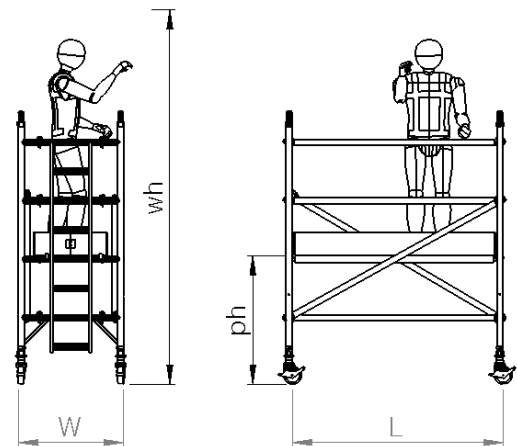
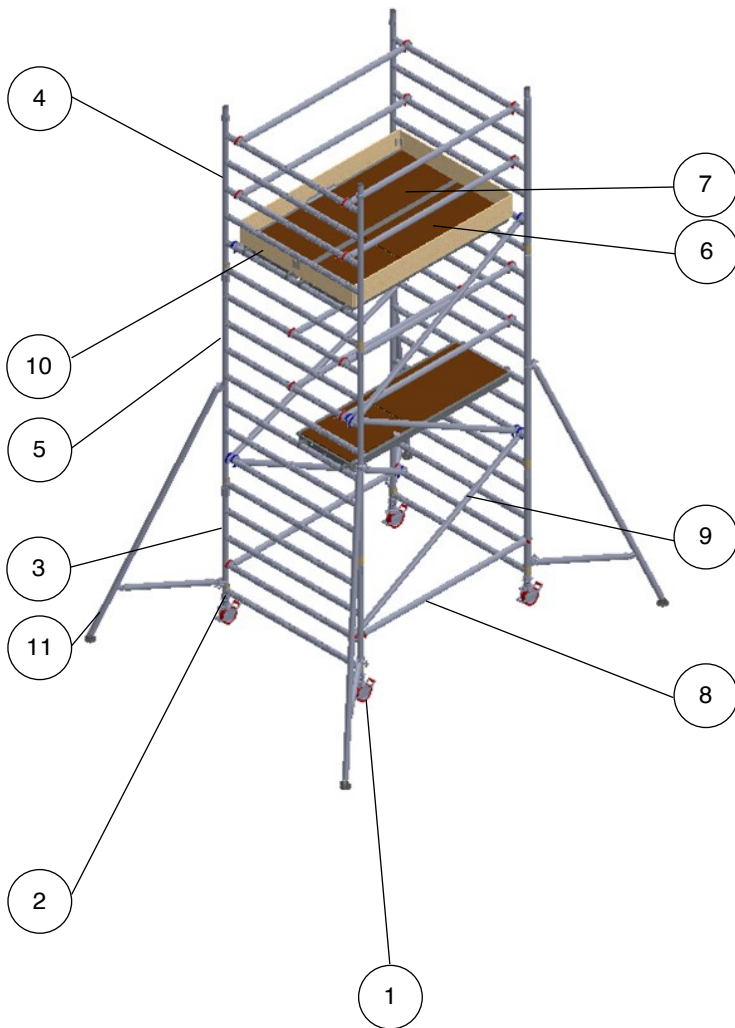

Technical information:

| | |
|---|--------------------|
| Base Dimensions: | (L)1.8m X (W)1.45m |
| Maximum Platform Height (ph): | 3.7m |
| Maximum Working Height (wh): | 5.7m |
| Maximum Working Load Per Platform: | 275kg |
| Maximum Working Load Per Tower: (including tower weight) | 950kg |
| Weight: | 154.3kg |

| | | |
|---|-------------------------------|--------------------------------|
| Double Width Tower 1.8m Long x 1.45m Wide | Working Height 6.2m | Platform Height 4.2m |
|---|-------------------------------|--------------------------------|

Tower Components

| Item | Description | Quantity |
|------|---|----------|
| 1 | 150mm Locking Caster | 4 |
| 2 | Adjustable Leg 500mm | 4 |
| 3 | 1m 4 Rung Frame | 2 |
| 4 | 1.5m 6 Rung Frame | 0 |
| 5 | 2m 8 Rung Frame | 4 |
| 6 | 1.8m Trapdoor Platform | 2 |
| 7 | 1.8m Fixed Platform | 1 |
| 8 | 1.8m Horizontal Brace | 10 |
| 9 | 2.1m Diagonal Brace | 7 |
| 10 | Complete Toe Board Set | 1 |
| 11 | S1 Stabiliser | 4 |
| 12 | S2 Stabiliser | 0 |
| 13 | Instruction Manual & EN1004:-1:2020 certificate of conformity | 1 |

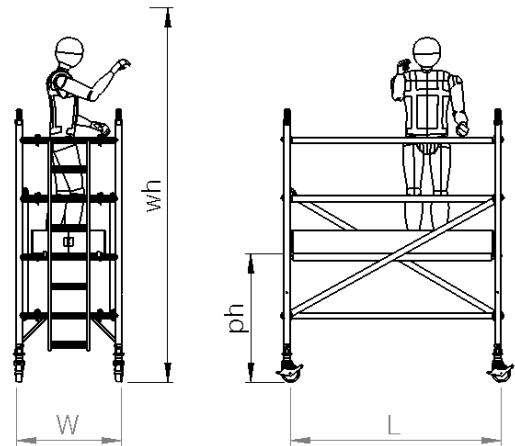
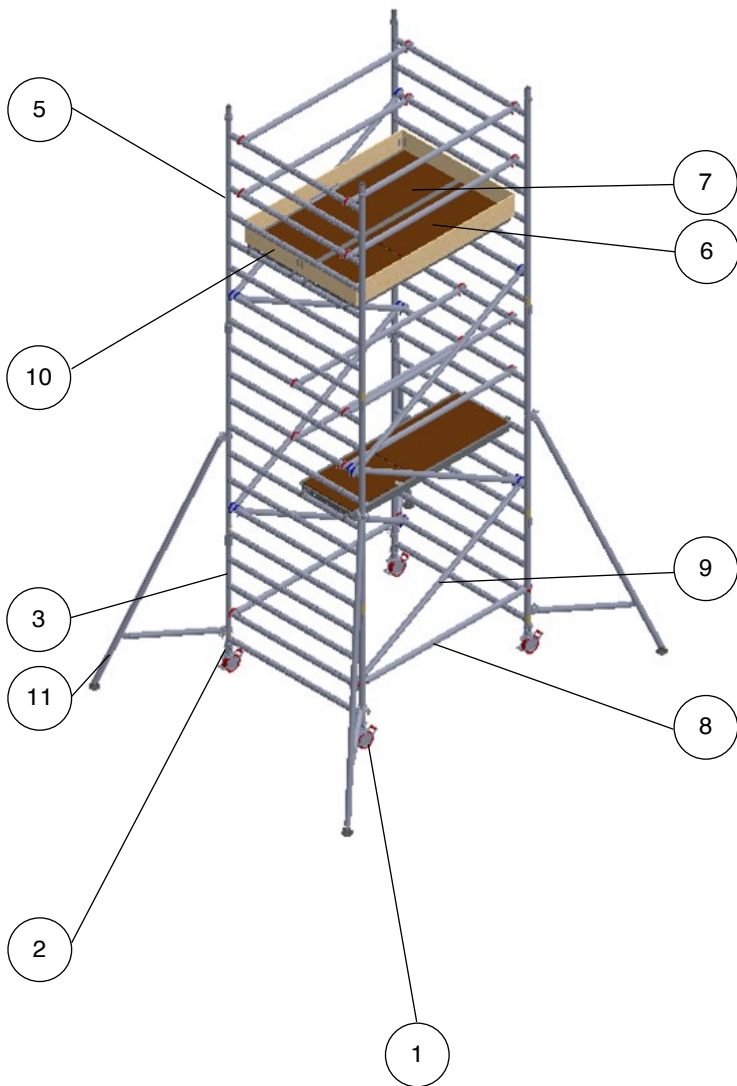

Technical information:

| | |
|---|--------------------|
| Base Dimensions: | (L)1.8m X (W)1.45m |
| Maximum Platform Height (ph): | 4.2m |
| Maximum Working Height (wh): | 6.2m |
| Maximum Working Load Per Platform: | 275kg |
| Maximum Working Load Per Tower: (including tower weight) | 950kg |
| Weight: | 160.4kg |

| | | |
|---|-------------------------------|--------------------------------|
| Double Width Tower 1.8m Long x 1.45m Wide | Working Height 6.7m | Platform Height 4.7m |
|---|-------------------------------|--------------------------------|

Tower Components

| Item | Description | Quantity |
|------|---|----------|
| 1 | 150mm Locking Caster | 4 |
| 2 | Adjustable Leg 500mm | 4 |
| 3 | 1m 4 Rung Frame | 0 |
| 4 | 1.5m 6 Rung Frame | 2 |
| 5 | 2m 8 Rung Frame | 4 |
| 6 | 1.8m Trapdoor Platform | 2 |
| 7 | 1.8m Fixed Platform | 1 |
| 8 | 1.8m Horizontal Brace | 10 |
| 9 | 2.1m Diagonal Brace | 8 |
| 10 | Complete Toe Board Set | 1 |
| 11 | S1 Stabiliser | 4 |
| 12 | S2 Stabiliser | 0 |
| 13 | Instruction Manual & EN1004:-1:2020 certificate of conformity | 1 |

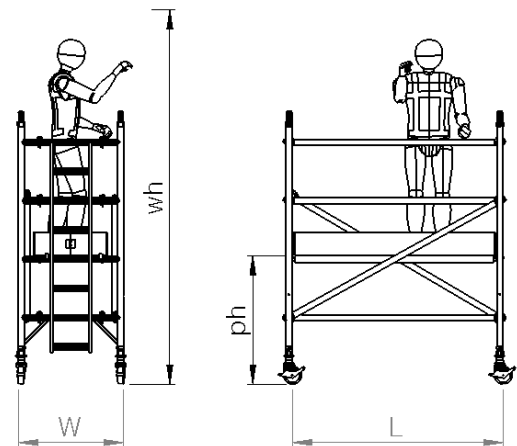
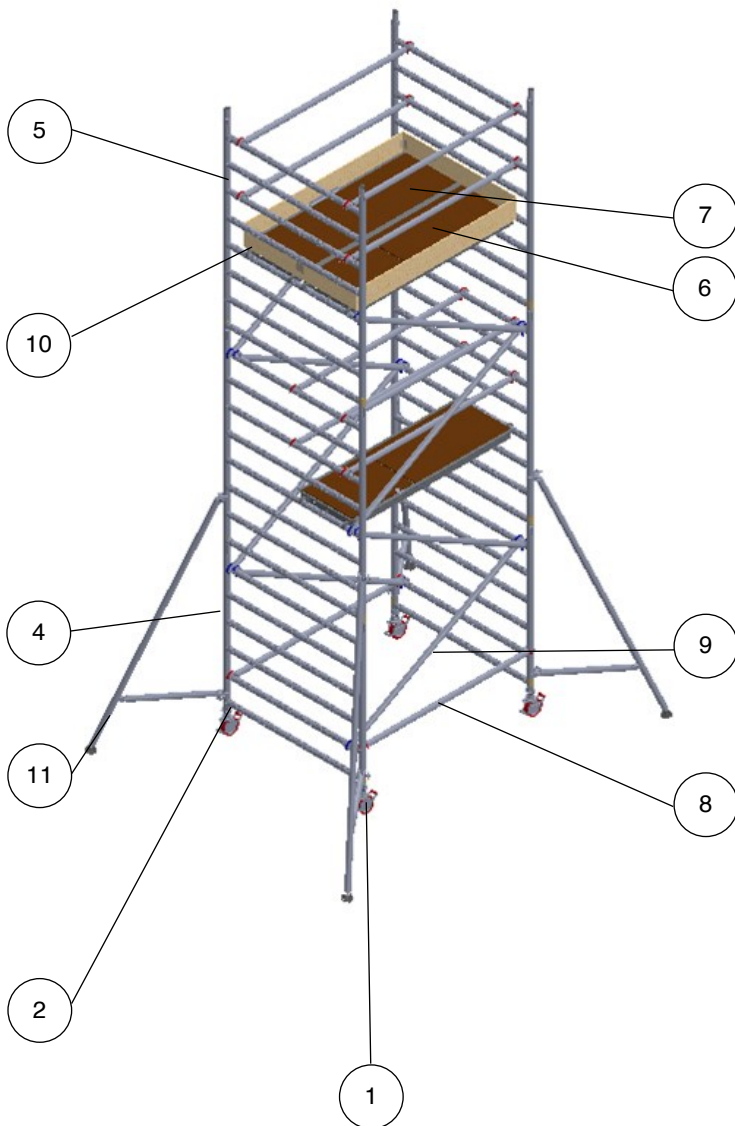

Technical information:

| | |
|---|--------------------|
| Base Dimensions: | (L)1.8m X (W)1.45m |
| Maximum Platform Height (ph): | 4.7m |
| Maximum Working Height (wh): | 6.7m |
| Maximum Working Load Per Platform: | 275kg |
| Maximum Working Load Per Tower: (including tower weight) | 950kg |
| Weight: | 166.8kg |



SERVICE YOU CAN TRUST

| | | |
|---|-------------------------------|--------------------------------|
| Double Width Tower 1.8m Long x 1.45m Wide | Working Height 7.2m | Platform Height 5.2m |
|---|-------------------------------|--------------------------------|

Tower Components

| Item | Description | Quantity |
|------|---|----------|
| 1 | 150mm Locking Caster | 4 |
| 2 | Adjustable Leg 500mm | 4 |
| 3 | 1m 4 Rung Frame | 0 |
| 4 | 1.5m 6 Rung Frame | 0 |
| 5 | 2m 8 Rung Frame | 6 |
| 6 | 1.8m Trapdoor Platform | 3 |
| 7 | 1.8m Fixed Platform | 1 |
| 8 | 1.8m Horizontal Brace | 14 |
| 9 | 2.1m Diagonal Brace | 9 |
| 10 | Complete Toe Board Set | 1 |
| 11 | S1 Stabiliser | 4 |
| 12 | S2 Stabiliser | 0 |
| 13 | Instruction Manual & EN1004:-1:2020 certificate of conformity | 1 |

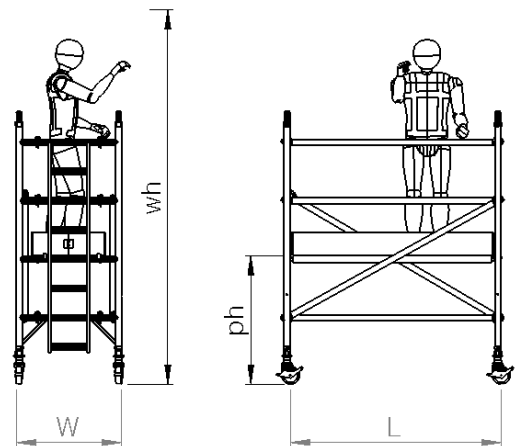
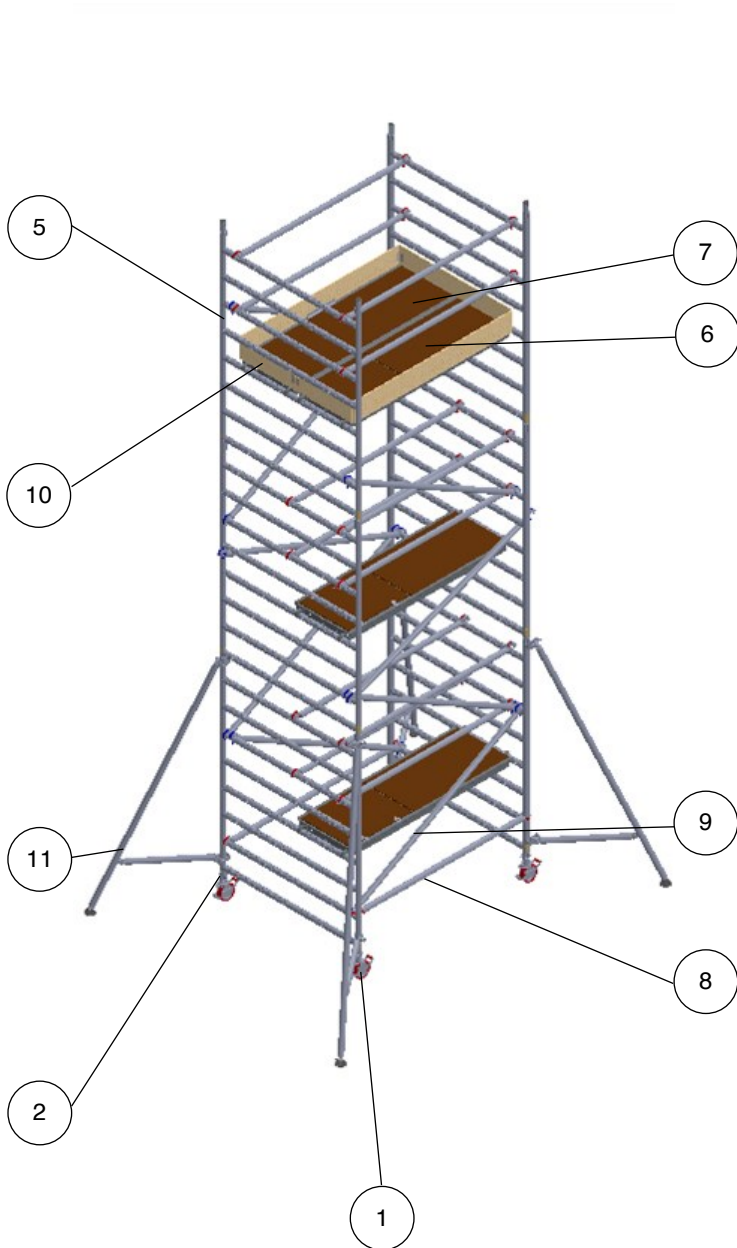

Technical information:

| | |
|---|--------------------|
| Base Dimensions: | (L)1.8m X (W)1.45m |
| Maximum Platform Height (ph): | 5.2m |
| Maximum Working Height (wh): | 7.2m |
| Maximum Working Load Per Platform: | 275kg |
| Maximum Working Load Per Tower: (including tower weight) | 950kg |
| Weight: | 194kg |

Mr Plant Hire
120 Hertford Road Enfield
London EN3 5AX

☎ 020 8351 3434
✉ info@mrplanthire.co.uk



| | | |
|---|-------------------------------|--------------------------------|
| Double Width Tower 1.8m Long x 1.45m Wide | Working Height 7.7m | Platform Height 5.7m |
|---|-------------------------------|--------------------------------|

Tower Components

| Item | Description | Quantity |
|------|---|----------|
| 1 | 150mm Locking Caster | 4 |
| 2 | Adjustable Leg 500mm | 4 |
| 3 | 1m 4 Rung Frame | 2 |
| 4 | 1.5m 6 Rung Frame | 2 |
| 5 | 2m 8 Rung Frame | 4 |
| 6 | 1.8m Trapdoor Platform | 3 |
| 7 | 1.8m Fixed Platform | 1 |
| 8 | 1.8m Horizontal Brace | 14 |
| 9 | 2.1m Diagonal Brace | 10 |
| 10 | Complete Toe Board Set | 1 |
| 11 | S1 Stabiliser | 4 |
| 12 | S2 Stabiliser | 0 |
| 13 | Instruction Manual & EN1004:-1:2020 certificate of conformity | 1 |

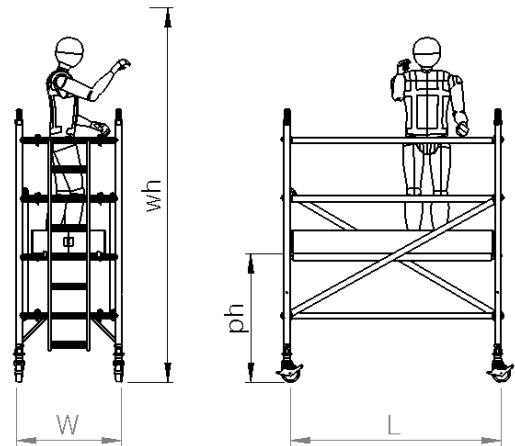
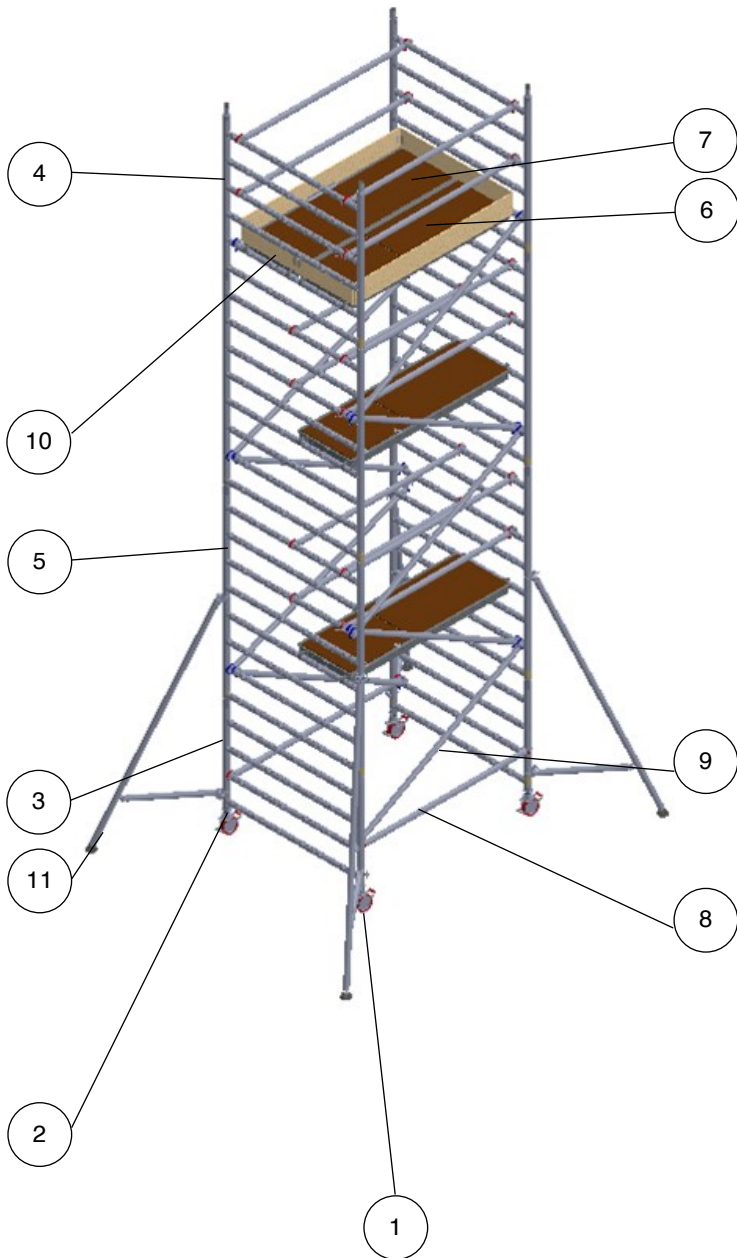

Technical information:

| | |
|---|--------------------|
| Base Dimensions: | (L)1.8m X (W)1.45m |
| Maximum Platform Height (ph): | 5.7m |
| Maximum Working Height (wh): | 7.7m |
| Maximum Working Load Per Platform: | 275kg |
| Maximum Working Load Per Tower: (including tower weight) | 950kg |
| Weight: | 201.7kg |

| | | |
|---|-------------------------------|--------------------------------|
| Double Width Tower 1.8m Long x 1.45m Wide | Working Height 8.2m | Platform Height 6.2m |
|---|-------------------------------|--------------------------------|

Tower Components

| Item | Description | Quantity |
|------|---|----------|
| 1 | 150mm Locking Caster | 4 |
| 2 | Adjustable Leg 500mm | 4 |
| 3 | 1m 4 Rung Frame | 2 |
| 4 | 1.5m 6 Rung Frame | 0 |
| 5 | 2m 8 Rung Frame | 6 |
| 6 | 1.8m Trapdoor Platform | 3 |
| 7 | 1.8m Fixed Platform | 1 |
| 8 | 1.8m Horizontal Brace | 14 |
| 9 | 2.1m Diagonal Brace | 11 |
| 10 | Complete Toe Board Set | 1 |
| 11 | S1 Stabiliser | 4 |
| 12 | S2 Stabiliser | 0 |
| 13 | Instruction Manual & EN1004:-1:2020 certificate of conformity | 1 |

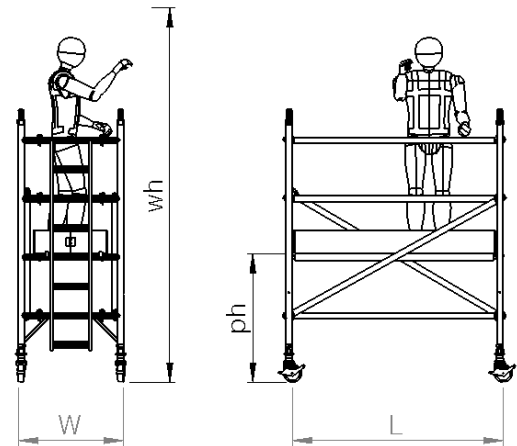
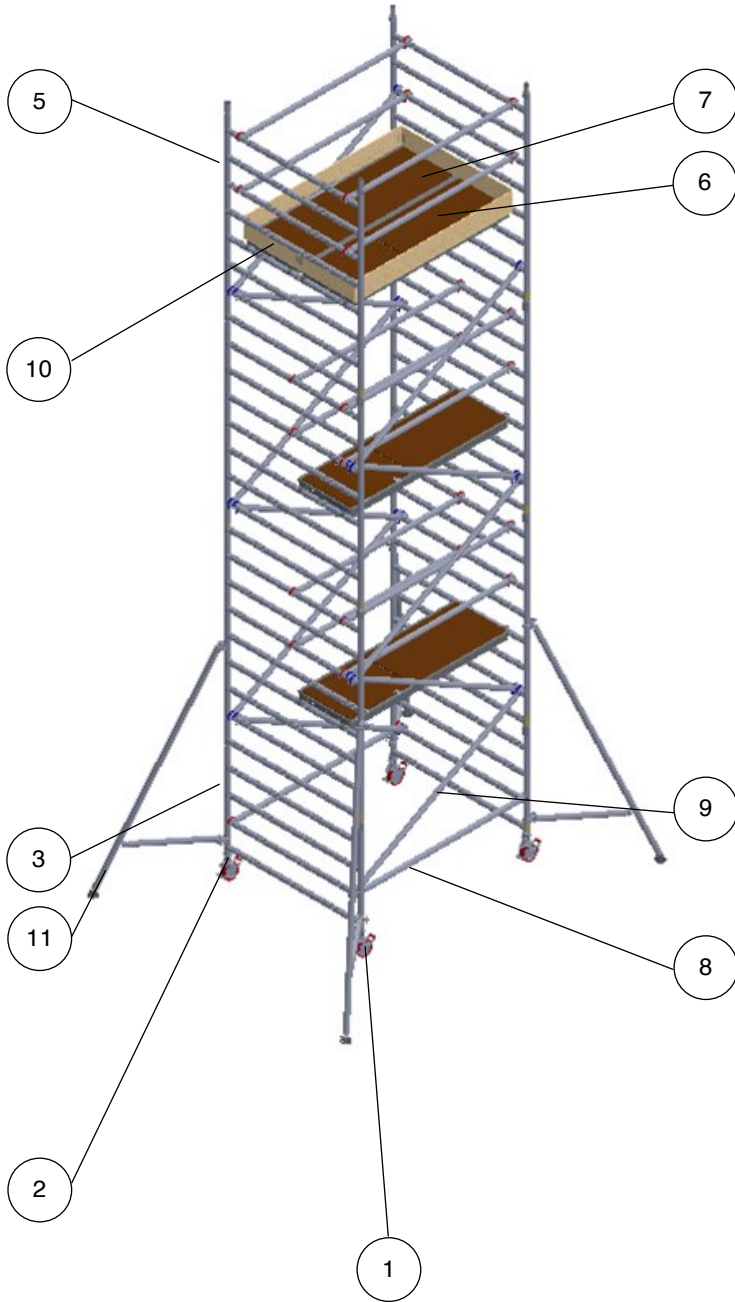

Technical information:

| | |
|---|--------------------|
| Base Dimensions: | (L)1.8m X (W)1.45m |
| Maximum Platform Height (ph): | 6.2m |
| Maximum Working Height (wh): | 8.2m |
| Maximum Working Load Per Platform: | 275kg |
| Maximum Working Load Per Tower: (including tower weight) | 950kg |
| Weight: | 207.8kg |

| | | |
|---|-------------------------------|--------------------------------|
| Double Width Tower 1.8m Long x 1.45m Wide | Working Height 8.7m | Platform Height 6.7m |
|---|-------------------------------|--------------------------------|

Tower Components

| Item | Description | Quantity |
|------|---|----------|
| 1 | 150mm Locking Caster | 4 |
| 2 | Adjustable Leg 500mm | 4 |
| 3 | 1m 4 Rung Frame | 0 |
| 4 | 1.5m 6 Rung Frame | 2 |
| 5 | 2m 8 Rung Frame | 6 |
| 6 | 1.8m Trapdoor Platform | 3 |
| 7 | 1.8m Fixed Platform | 1 |
| 8 | 1.8m Horizontal Brace | 14 |
| 9 | 2.1m Diagonal Brace | 12 |
| 10 | Complete Toe Board Set | 1 |
| 11 | S1 Stabiliser | 4 |
| 12 | S2 Stabiliser | 0 |
| 13 | Instruction Manual & EN1004:-1:2020 certificate of conformity | 1 |

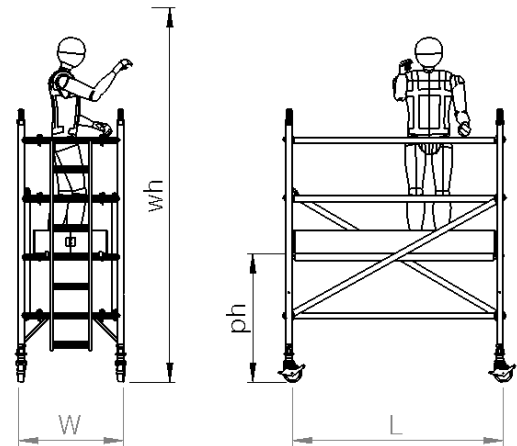
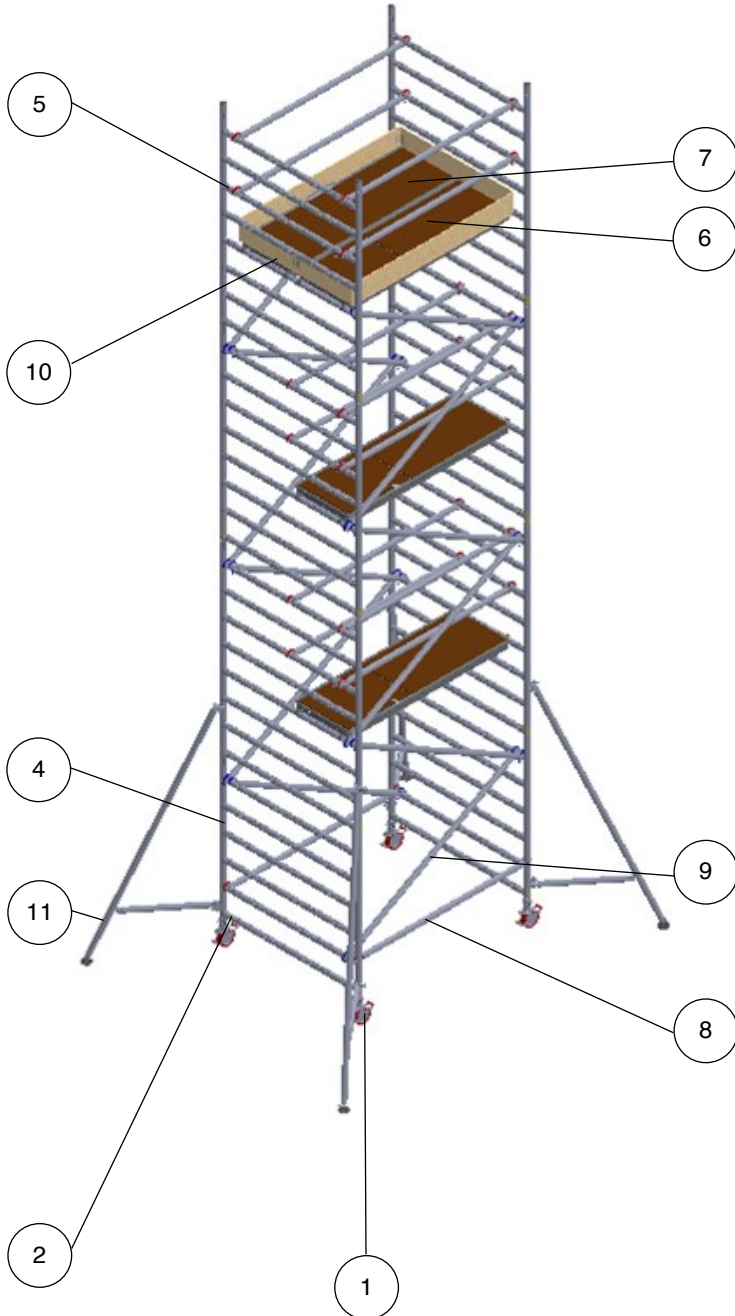

Technical information:

| | |
|---|--------------------|
| Base Dimensions: | (L)1.8m X (W)1.45m |
| Maximum Platform Height (ph): | 6.7m |
| Maximum Working Height (wh): | 8.7m |
| Maximum Working Load Per Platform: | 275kg |
| Maximum Working Load Per Tower: (including tower weight) | 950kg |
| Weight: | 214.2kg |



SERVICE YOU CAN TRUST

| | | |
|---|-------------------------------|--------------------------------|
| Double Width Tower 1.8m Long x 1.45m Wide | Working Height 9.2m | Platform Height 7.2m |
|---|-------------------------------|--------------------------------|

Tower Components

| Item | Description | Quantity |
|------|---|----------|
| 1 | 150mm Locking Caster | 4 |
| 2 | Adjustable Leg 500mm | 4 |
| 3 | 1m 4 Rung Frame | 0 |
| 4 | 1.5m 6 Rung Frame | 0 |
| 5 | 2m 8 Rung Frame | 8 |
| 6 | 1.8m Trapdoor Platform | 4 |
| 7 | 1.8m Fixed Platform | 1 |
| 8 | 1.8m Horizontal Brace | 18 |
| 9 | 2.1m Diagonal Brace | 13 |
| 10 | Complete Toe Board Set | 1 |
| 11 | S1 Stabiliser | 4 |
| 12 | S2 Stabiliser | 0 |
| 13 | Instruction Manual & EN1004:-1:2020 certificate of conformity | 1 |

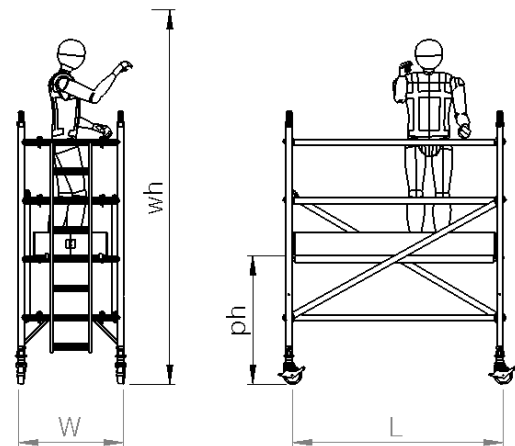
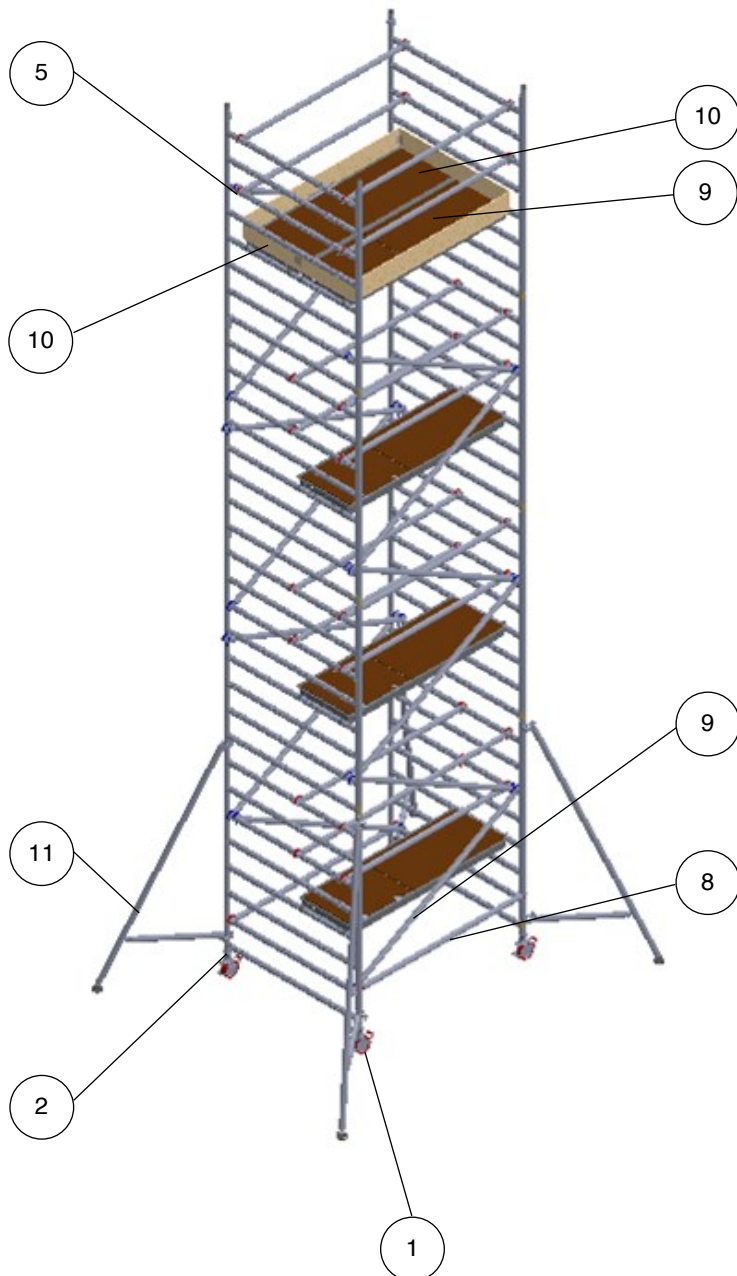

Technical information:

| | |
|---|--------------------|
| Base Dimensions: | (L)1.8m X (W)1.45m |
| Maximum Platform Height (ph): | 7.2m |
| Maximum Working Height (wh): | 9.2m |
| Maximum Working Load Per Platform: | 275kg |
| Maximum Working Load Per Tower: (including tower weight) | 950kg |
| Weight: | 241.4kg |

Mr Plant Hire
120 Hertford Road Enfield
London EN3 5AX

☎ 020 8351 3434
✉ info@mrplanthire.co.uk





SERVICE YOU CAN TRUST

| | | |
|---|-------------------------------|--------------------------------|
| Double Width Tower 1.8m Long x 1.45m Wide | Working Height 9.7m | Platform Height 7.7m |
|---|-------------------------------|--------------------------------|

Tower Components

| Item | Description | Quantity |
|------|---|----------|
| 1 | 150mm Locking Caster | 4 |
| 2 | Adjustable Leg 500mm | 4 |
| 3 | 1m 4 Rung Frame | 2 |
| 4 | 1.5m 6 Rung Frame | 2 |
| 5 | 2m 8 Rung Frame | 6 |
| 6 | 1.8m Trapdoor Platform | 4 |
| 7 | 1.8m Fixed Platform | 1 |
| 8 | 1.8m Horizontal Brace | 18 |
| 9 | 2.1m Diagonal Brace | 14 |
| 10 | Complete Toe Board Set | 1 |
| 11 | S1 Stabiliser | 4 |
| 12 | S2 Stabiliser | 0 |
| 13 | Instruction Manual & EN1004:-1:2020 certificate of conformity | 1 |

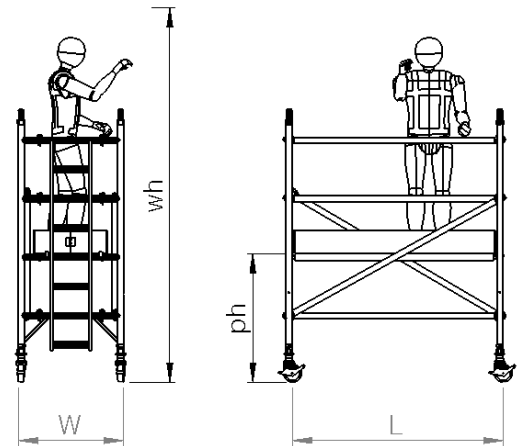
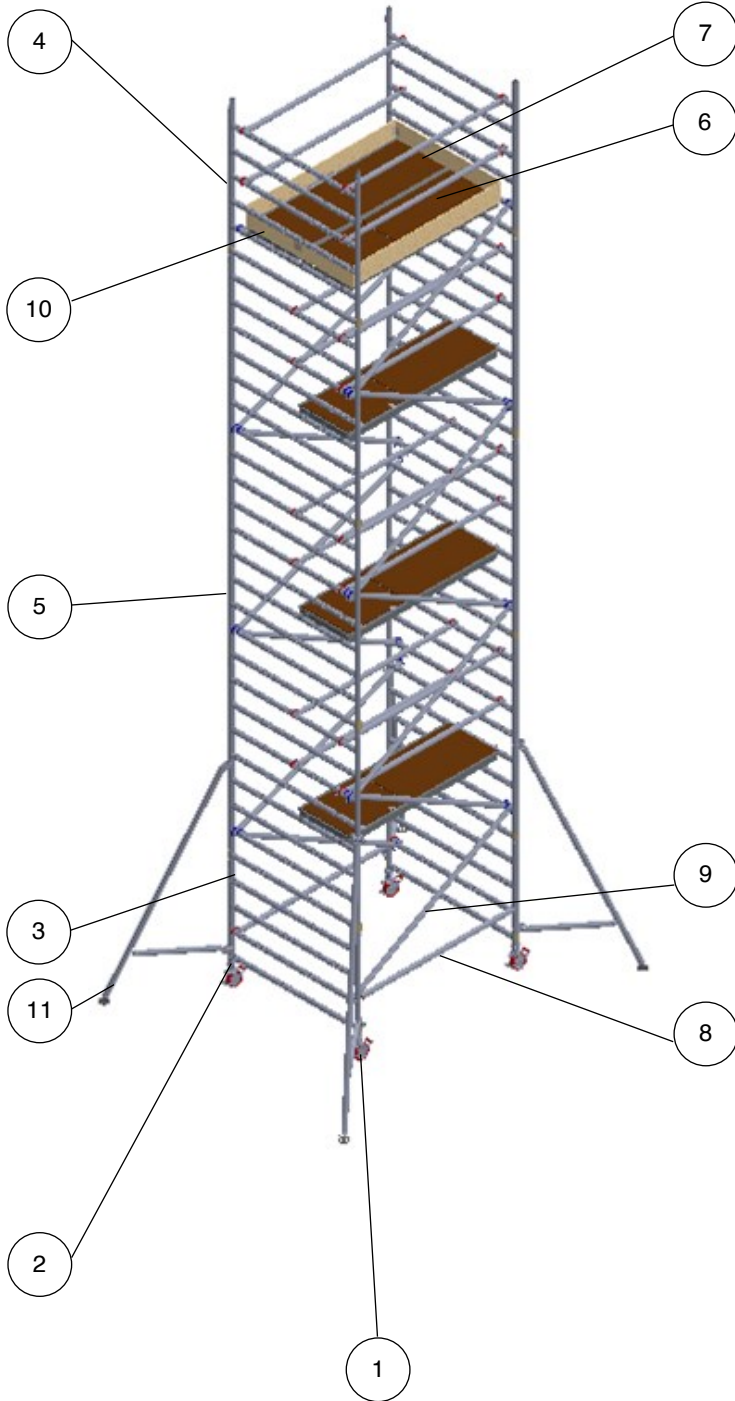

Technical information:

| | |
|---|--------------------|
| Base Dimensions: | (L)1.8m X (W)1.45m |
| Maximum Platform Height (ph): | 7.7m |
| Maximum Working Height (wh): | 9.7m |
| Maximum Working Load Per Platform: | 275kg |
| Maximum Working Load Per Tower: (including tower weight) | 950kg |
| Weight: | 249.1kg |

Mr Plant Hire
120 Hertford Road Enfield
London EN3 5AX

☎ 020 8351 3434
✉ info@mrplanthire.co.uk





SERVICE YOU CAN TRUST

| | | |
|---|--------------------------------|--------------------------------|
| Double Width Tower 1.8m Long x 1.45m Wide | Working Height 10.2m | Platform Height 8.2m |
|---|--------------------------------|--------------------------------|

Tower Components

| Item | Description | Quantity |
|------|---|----------|
| 1 | 150mm Locking Caster | 4 |
| 2 | Adjustable Leg 500mm | 4 |
| 3 | 1m 4 Rung Frame | 2 |
| 4 | 1.5m 6 Rung Frame | 0 |
| 5 | 2m 8 Rung Frame | 8 |
| 6 | 1.8m Trapdoor Platform | 4 |
| 7 | 1.8m Fixed Platform | 1 |
| 8 | 1.8m Horizontal Brace | 18 |
| 9 | 2.1m Diagonal Brace | 15 |
| 10 | Complete Toe Board Set | 1 |
| 11 | S1 Stabiliser | 4 |
| 12 | S2 Stabiliser | 0 |
| 13 | Instruction Manual & EN1004:-1:2020 certificate of conformity | 1 |

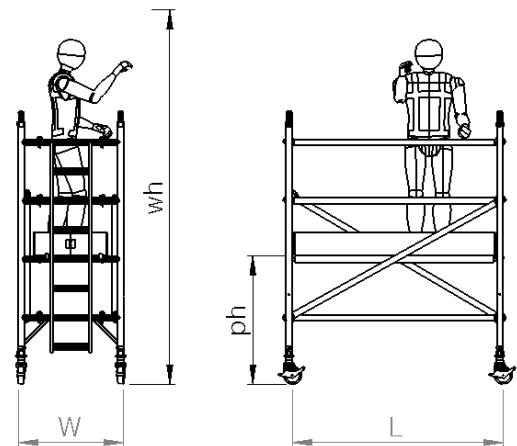
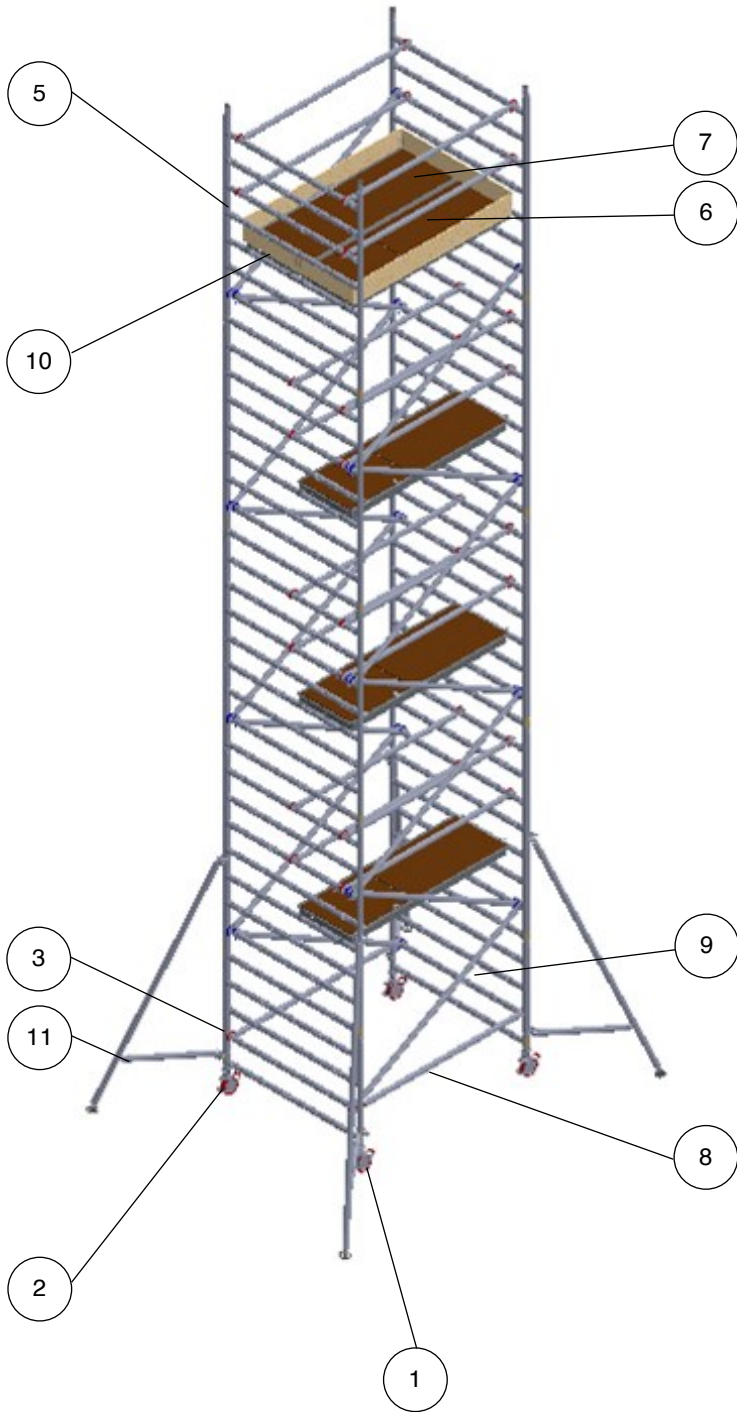

Technical information:

| | |
|---|--------------------|
| Base Dimensions: | (L)1.8m X (W)1.45m |
| Maximum Platform Height (ph): | 8.2m |
| Maximum Working Height (wh): | 10.2m |
| Maximum Working Load Per Platform: | 275kg |
| Maximum Working Load Per Tower: (including tower weight) | 950kg |
| Weight: | 255.2kg |

Mr Plant Hire
120 Hertford Road Enfield
London EN3 5AX

☎ 020 8351 3434
✉ info@mrplanthire.co.uk





SERVICE YOU CAN TRUST

| | | |
|---|--------------------------------|--------------------------------|
| Double Width Tower 1.8m Long x 1.45m Wide | Working Height 10.7m | Platform Height 8.7m |
|---|--------------------------------|--------------------------------|

Tower Components

| Item | Description | Quantity |
|------|---|----------|
| 1 | 150mm Locking Caster | 4 |
| 2 | Adjustable Leg 500mm | 4 |
| 3 | 1m Ladder Frame | 0 |
| 6 | 1.5m Span Frame | 2 |
| 7 | 2m Ladder Frame | 8 |
| 9 | 1.8m Trapdoor Platform | 4 |
| 10 | 1.8m Fixed Platform | 1 |
| 11 | 1.8m Horizontal Brace | 18 |
| 12 | 2.1m Diagonal Brace | 16 |
| 13 | Complete Toe Board Set | 1 |
| 14 | S1 Stabiliser | 0 |
| 15 | S2 Stabiliser | 4 |
| 16 | Instruction Manual & EN1004:-1:2020 certificate of conformity | 1 |

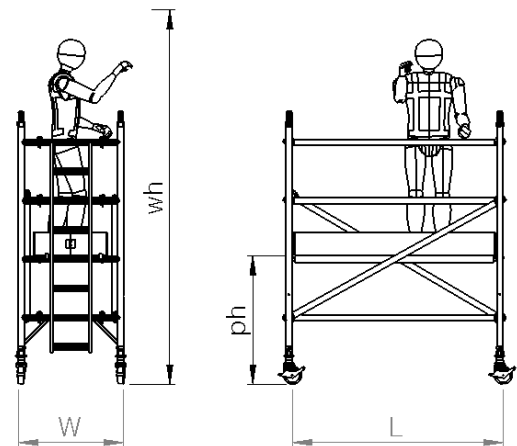
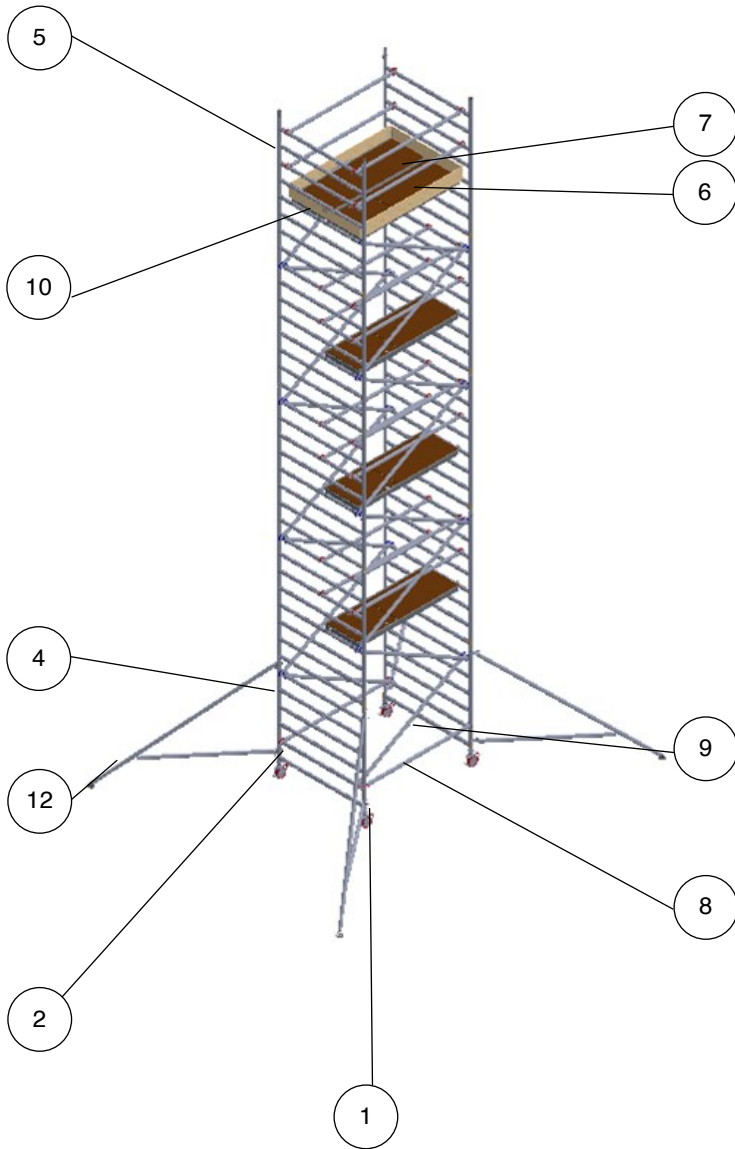

Technical information:

| | |
|---|--------------------|
| Base Dimensions: | (L)1.8m X (W)1.45m |
| Maximum Platform Height (ph): | 8.7m |
| Maximum Working Height (wh): | 10.7m |
| Maximum Working Load Per Platform: | 275kg |
| Maximum Working Load Per Tower: (including tower weight) | 950kg |
| Weight: | 268.8kg |

| | | |
|---|--------------------------------|--------------------------------|
| Double Width Tower 1.8m Long x 1.45m Wide | Working Height 11.2m | Platform Height 9.2m |
|---|--------------------------------|--------------------------------|

Tower Components

| Item | Description | Quantity |
|------|---|----------|
| 1 | 150mm Locking Caster | 4 |
| 2 | Adjustable Leg 500mm | 4 |
| 3 | 1m 4 Rung Frame | 0 |
| 4 | 1.5m 6 Rung Frame | 0 |
| 5 | 2m 8 Rung Frame | 10 |
| 6 | 1.8m Trapdoor Platform | 5 |
| 7 | 1.8m Fixed Platform | 1 |
| 8 | 1.8m Horizontal Brace | 22 |
| 9 | 2.1m Diagonal Brace | 17 |
| 10 | Complete Toe Board Set | 1 |
| 11 | S1 Stabiliser | 0 |
| 12 | S2 Stabiliser | 4 |
| 13 | Instruction Manual & EN1004:-1:2020 certificate of conformity | 1 |

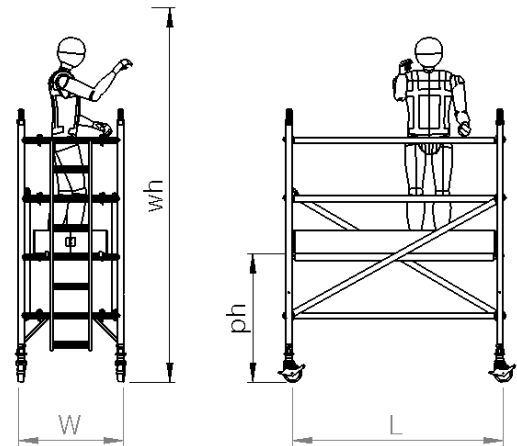
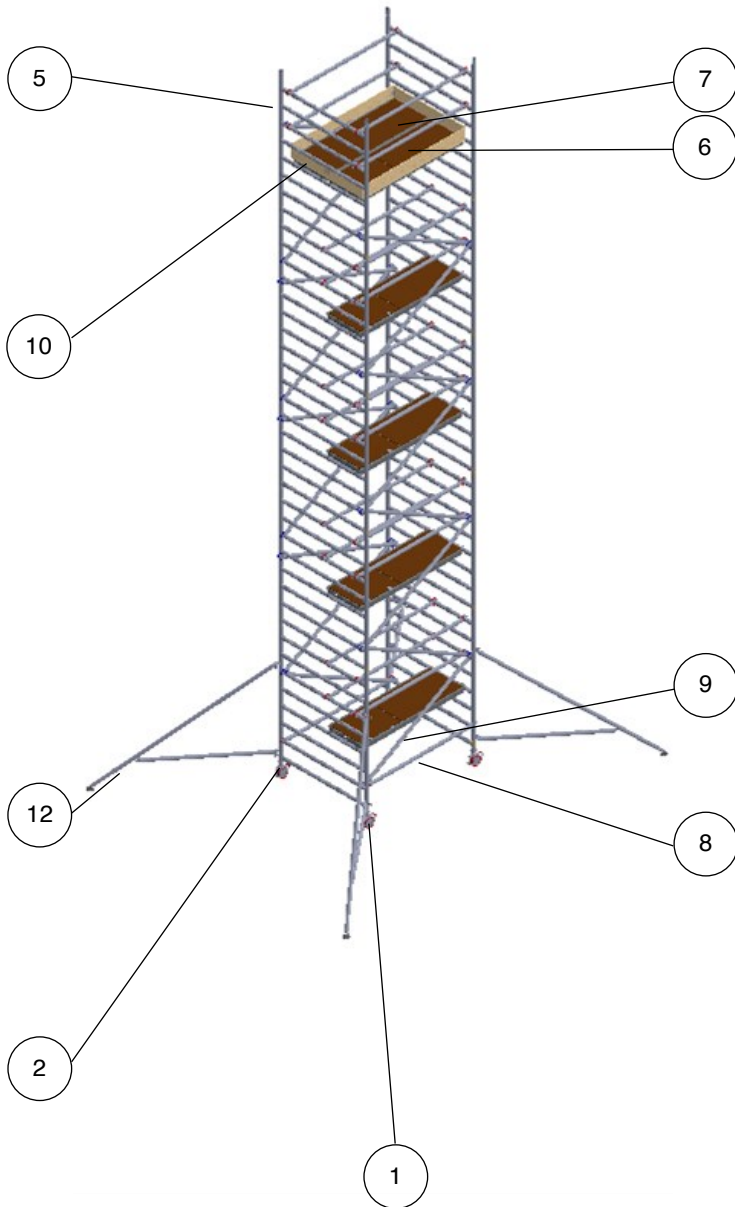

Technical information:

| | |
|---|--------------------|
| Base Dimensions: | (L)1.8m X (W)1.45m |
| Maximum Platform Height (ph): | 9.2m |
| Maximum Working Height (wh): | 11.2m |
| Maximum Working Load Per Platform: | 275kg |
| Maximum Working Load Per Tower: (including tower weight) | 950kg |
| Weight: | 296kg |



SERVICE YOU CAN TRUST

| | | |
|---|--------------------------------|--------------------------------|
| Double Width Tower 1.8m Long x 1.45m Wide | Working Height 11.7m | Platform Height 9.7m |
|---|--------------------------------|--------------------------------|

Tower Components

| Item | Description | Quantity |
|------|---|----------|
| 1 | 150mm Locking Caster | 4 |
| 2 | Adjustable Leg 500mm | 4 |
| 3 | 1m 4 Rung Frame | 2 |
| 4 | 1.5m 6 Rung Frame | 2 |
| 5 | 2m 8 Rung Frame | 8 |
| 6 | 1.8m Trapdoor Platform | 5 |
| 7 | 1.8m Fixed Platform | 1 |
| 8 | 1.8m Horizontal Brace | 22 |
| 9 | 2.1m Diagonal Brace | 18 |
| 10 | Complete Toe Board Set | 1 |
| 11 | S1 Stabiliser | 0 |
| 12 | S2 Stabiliser | 4 |
| 13 | Instruction Manual & EN1004:-1:2020 certificate of conformity | 1 |

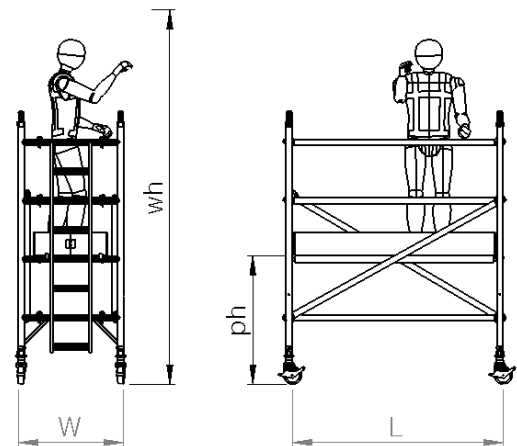
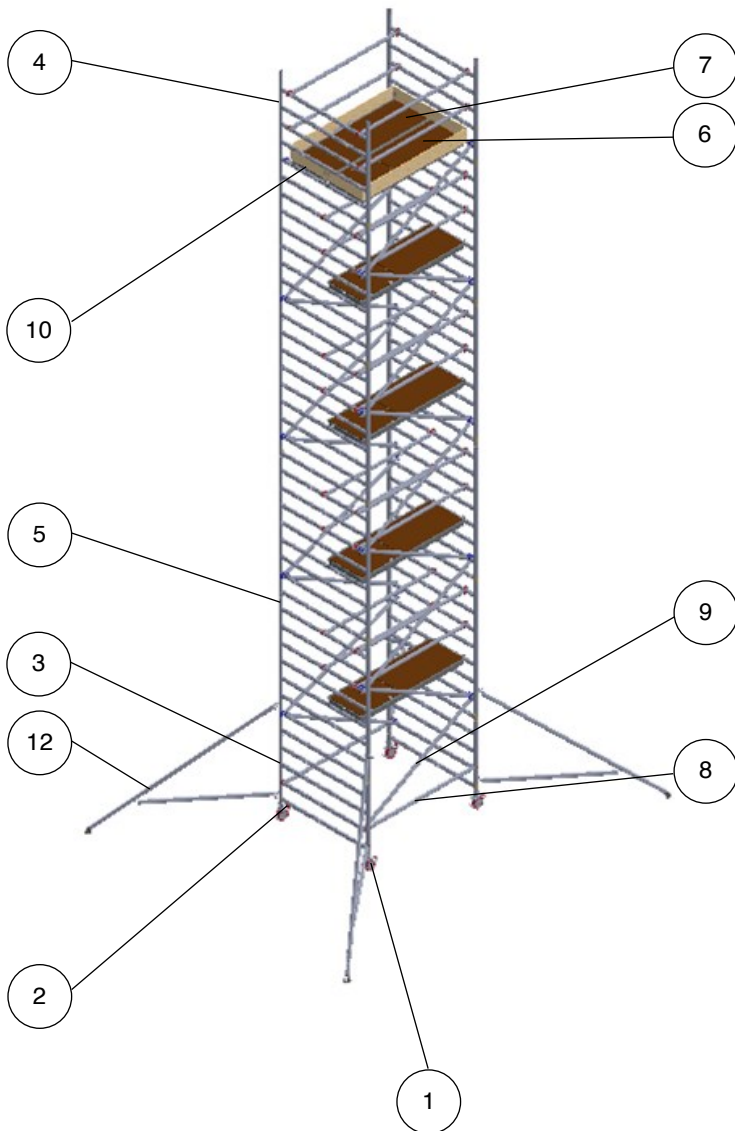

Technical information:

| | |
|---|--------------------|
| Base Dimensions: | (L)1.8m X (W)1.45m |
| Maximum Platform Height (ph): | 9.7m |
| Maximum Working Height (wh): | 11.7m |
| Maximum Working Load Per Platform: | 275kg |
| Maximum Working Load Per Tower: (including tower weight) | 950kg |
| Weight: | 303.7kg |

Mr Plant Hire
120 Hertford Road Enfield
London EN3 5AX

☎ 020 8351 3434
✉ info@mrplanthire.co.uk



| | | |
|---|--------------------------------|---------------------------------|
| Double Width Tower 1.8m Long x 1.45m Wide | Working Height 12.2m | Platform Height 10.2m |
|---|--------------------------------|---------------------------------|

Tower Components

| Item | Description | Quantity |
|------|---|----------|
| 1 | 150mm Locking Caster | 4 |
| 2 | Adjustable Leg 500mm | 4 |
| 3 | 1m 4 Rung Frame | 2 |
| 4 | 1.5m 6 Rung Frame | 0 |
| 5 | 2m 8 Rung Frame | 10 |
| 6 | 1.8m Trapdoor Platform | 5 |
| 7 | 1.8m Fixed Platform | 1 |
| 8 | 1.8m Horizontal Brace | 22 |
| 9 | 2.1m Diagonal Brace | 19 |
| 10 | Complete Toe Board Set | 1 |
| 11 | S1 Stabiliser | 0 |
| 12 | S2 Stabiliser | 4 |
| 13 | Instruction Manual & EN1004:-1:2020 certificate of conformity | 1 |

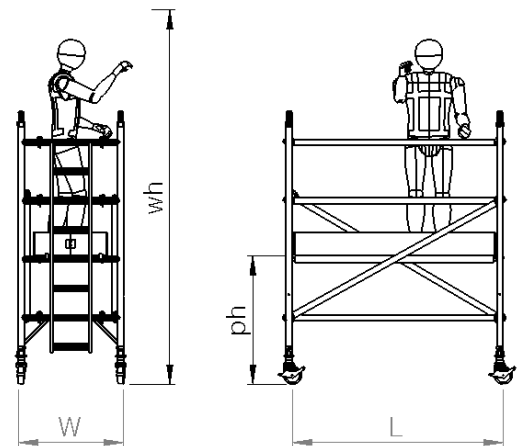
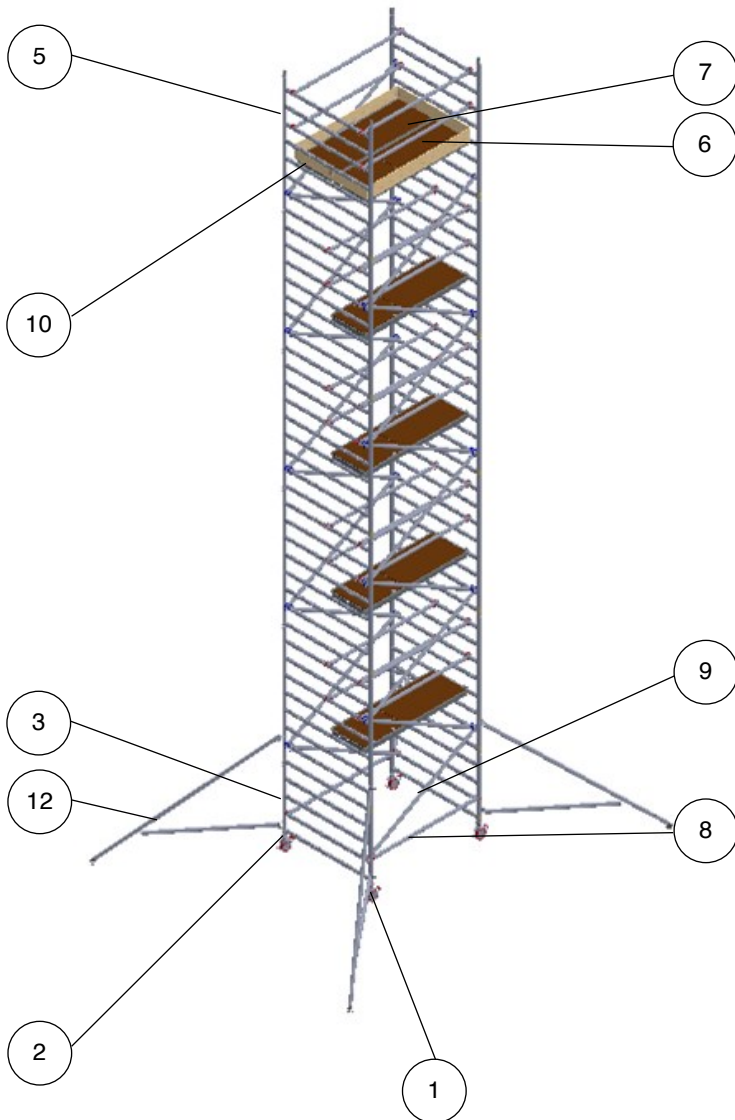

Technical information:

| | |
|---|--------------------|
| Base Dimensions: | (L)1.8m X (W)1.45m |
| Maximum Platform Height (ph): | 10.2m |
| Maximum Working Height (wh): | 12.2m |
| Maximum Working Load Per Platform: | 275kg |
| Maximum Working Load Per Tower: (including tower weight) | 950kg |
| Weight: | 309.8kg |



SERVICE YOU CAN TRUST

| | | |
|---|--------------------------------|---------------------------------|
| Double Width Tower 1.8m Long x 1.45m Wide | Working Height 12.7m | Platform Height 10.7m |
|---|--------------------------------|---------------------------------|

Tower Components

| Item | Description | Quantity |
|------|---|----------|
| 1 | 150mm Locking Caster | 4 |
| 2 | Adjustable Leg 500mm | 4 |
| 3 | 1m Ladder Frame | 0 |
| 6 | 1.5m Span Frame | 2 |
| 7 | 2m Ladder Frame | 10 |
| 9 | 1.8m Trapdoor Platform | 5 |
| 10 | 1.8m Fixed Platform | 1 |
| 11 | 1.8m Horizontal Brace | 22 |
| 12 | 2.1m Diagonal Brace | 20 |
| 13 | Complete Toe Board Set | 1 |
| 14 | S1 Stabiliser | 0 |
| 15 | S2 Stabiliser | 4 |
| 16 | Instruction Manual & EN1004:-1:2020 certificate of conformity | 1 |

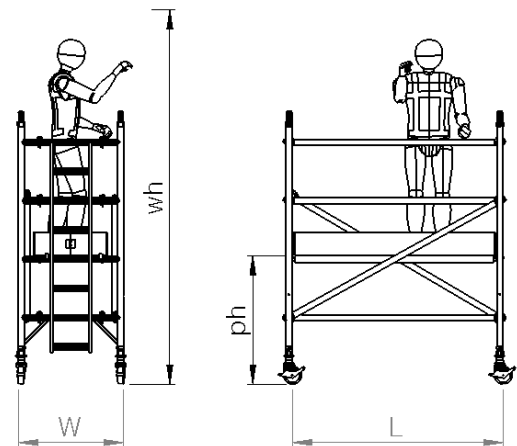
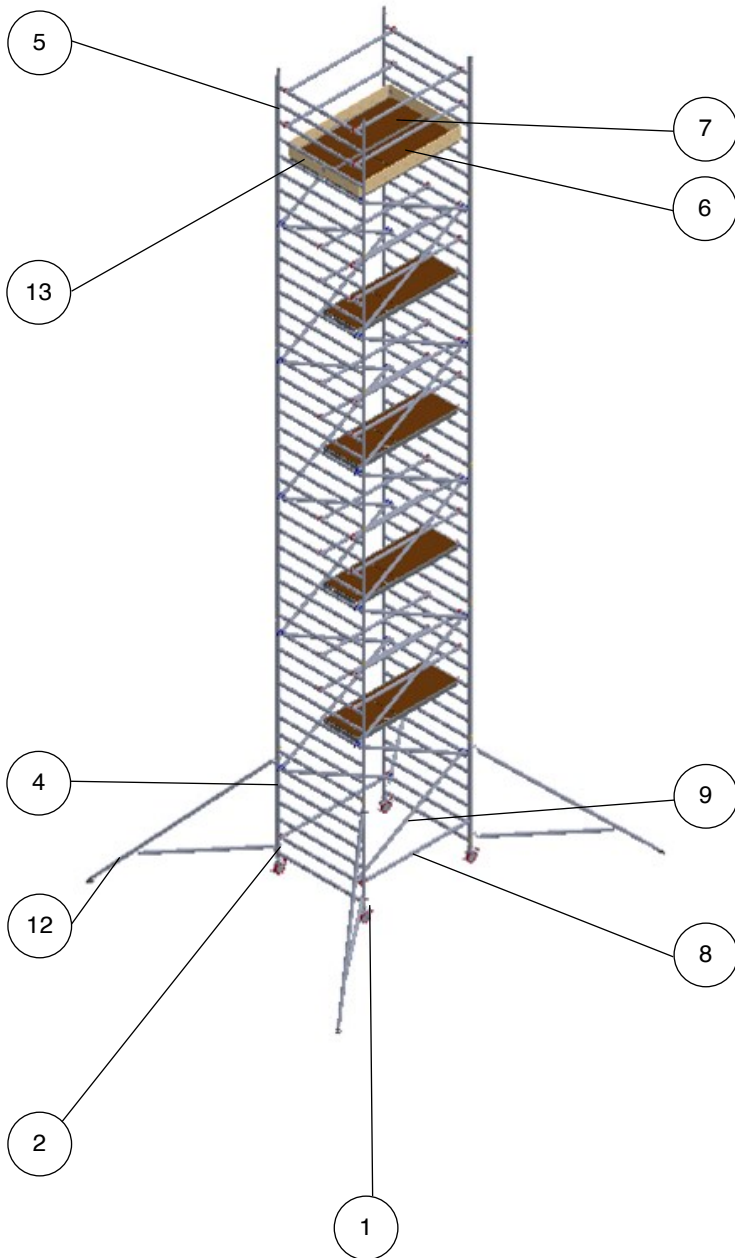

Technical information:

| | |
|---|--------------------|
| Base Dimensions: | (L)1.8m X (W)1.45m |
| Maximum Platform Height (ph): | 10.7m |
| Maximum Working Height (wh): | 12.7m |
| Maximum Working Load Per Platform: | 275kg |
| Maximum Working Load Per Tower: (including tower weight) | 950kg |
| Weight: | 316.2kg |

Mr Plant Hire
120 Hertford Road Enfield
London EN3 5AX

☎ 020 8351 3434
✉ info@mrplanthire.co.uk



| | | |
|---|--------------------------------|---------------------------------|
| Double Width Tower 1.8m Long x 1.45m Wide | Working Height 13.2m | Platform Height 11.2m |
|---|--------------------------------|---------------------------------|

Tower Components

| Item | Description | Quantity |
|------|---|----------|
| 1 | 150mm Locking Caster | 4 |
| 2 | Adjustable Leg 500mm | 4 |
| 3 | 1m 4 Rung Frame | 0 |
| 4 | 1.5m 6 Rung Frame | 0 |
| 5 | 2m 8 Rung Frame | 12 |
| 6 | 1.8m Trapdoor Platform | 6 |
| 7 | 1.8m Fixed Platform | 1 |
| 8 | 1.8m Horizontal Brace | 26 |
| 9 | 2.1m Diagonal Brace | 21 |
| 10 | Complete Toe Board Set | 1 |
| 11 | S1 Stabiliser | 0 |
| 12 | S2 Stabiliser | 4 |
| 13 | Instruction Manual & EN1004:-1:2020 certificate of conformity | 1 |

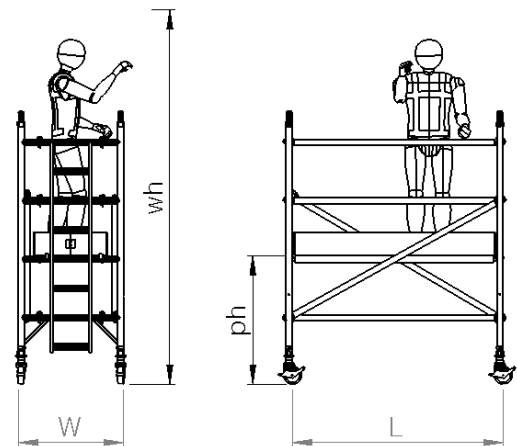
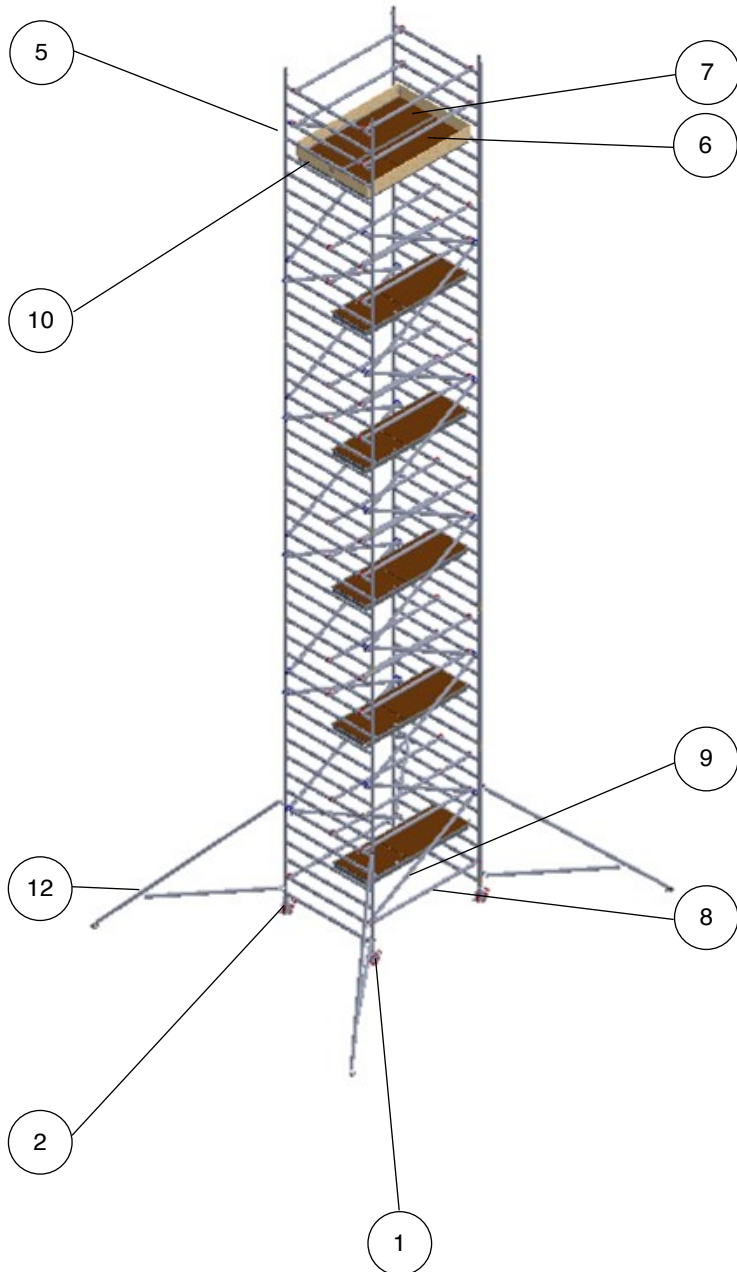

Technical information:

| | |
|---|--------------------|
| Base Dimensions: | (L)1.8m X (W)1.45m |
| Maximum Platform Height (ph): | 11.2m |
| Maximum Working Height (wh): | 13.2m |
| Maximum Working Load Per Platform: | 275kg |
| Maximum Working Load Per Tower: (including tower weight) | 950kg |
| Weight: | 343.4kg |



SERVICE YOU CAN TRUST

| | | |
|---|--------------------------------|---------------------------------|
| Double Width Tower 1.8m Long x 1.45m Wide | Working Height 13.7m | Platform Height 11.7m |
|---|--------------------------------|---------------------------------|

Tower Components

| Item | Description | Quantity |
|------|---|----------|
| 1 | 150mm Locking Caster | 4 |
| 2 | Adjustable Leg 500mm | 4 |
| 3 | 1m 4 Rung Frame | 2 |
| 4 | 1.5m 6 Rung Frame | 2 |
| 5 | 2m 8 Rung Frame | 10 |
| 6 | 1.8m Trapdoor Platform | 6 |
| 7 | 1.8m Fixed Platform | 1 |
| 8 | 1.8m Horizontal Brace | 26 |
| 9 | 2.1m Diagonal Brace | 22 |
| 10 | Complete Toe Board Set | 1 |
| 11 | S1 Stabiliser | 0 |
| 12 | S2 Stabiliser | 4 |
| 13 | Instruction Manual & EN1004:-1:2020 certificate of conformity | 1 |

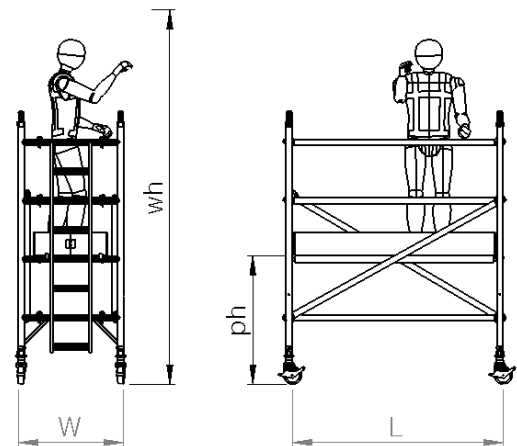
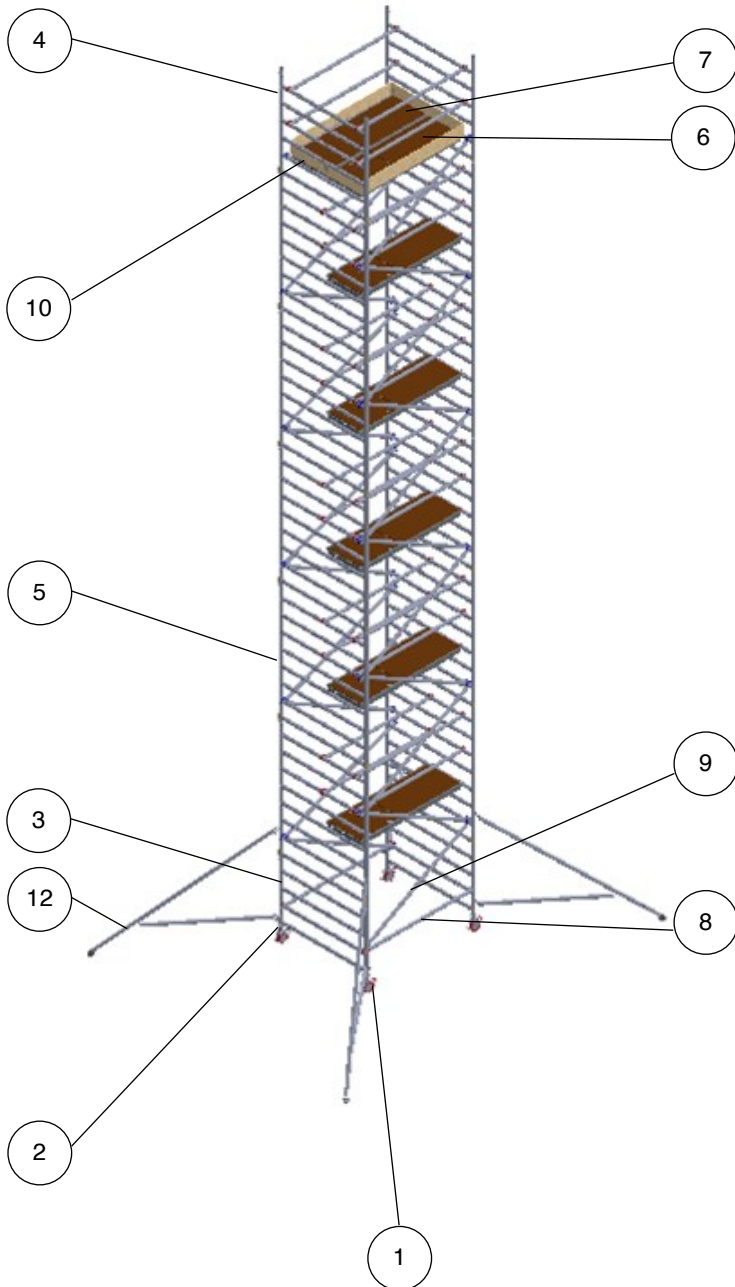

Technical information:

| | |
|---|--------------------|
| Base Dimensions: | (L)1.8m X (W)1.45m |
| Maximum Platform Height (ph): | 11.7m |
| Maximum Working Height (wh): | 13.7m |
| Maximum Working Load Per Platform: | 275kg |
| Maximum Working Load Per Tower: (including tower weight) | 950kg |
| Weight: | 351.1kg |

Mr Plant Hire
120 Hertford Road Enfield
London EN3 5AX

☎ 020 8351 3434
✉ info@mrplanthire.co.uk



| | | |
|---|--------------------------------|---------------------------------|
| Double Width Tower 1.8m Long x 1.45m Wide | Working Height 14.2m | Platform Height 12.2m |
|---|--------------------------------|---------------------------------|

Tower Components

| Item | Description | Quantity |
|------|---|----------|
| 1 | 150mm Locking Caster | 4 |
| 2 | Adjustable Leg 500mm | 4 |
| 3 | 1m 4 Rung Frame | 2 |
| 4 | 1.5m 6 Rung Frame | 0 |
| 5 | 2m 8 Rung Frame | 12 |
| 6 | 1.8m Trapdoor Platform | 6 |
| 7 | 1.8m Fixed Platform | 1 |
| 8 | 1.8m Horizontal Brace | 26 |
| 9 | 2.1m Diagonal Brace | 23 |
| 10 | Complete Toe Board Set | 1 |
| 11 | S1 Stabiliser | 0 |
| 12 | S2 Stabiliser | 4 |
| 13 | Instruction Manual & EN1004:-1:2020 certificate of conformity | 1 |

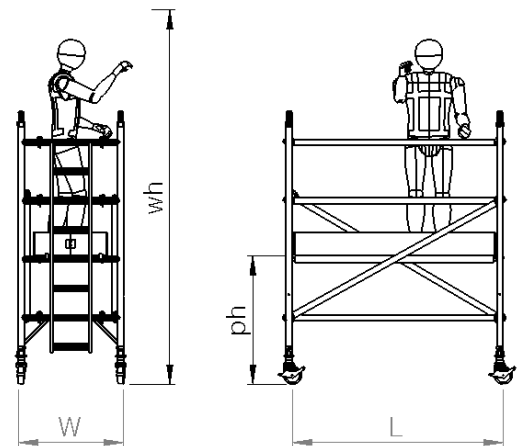
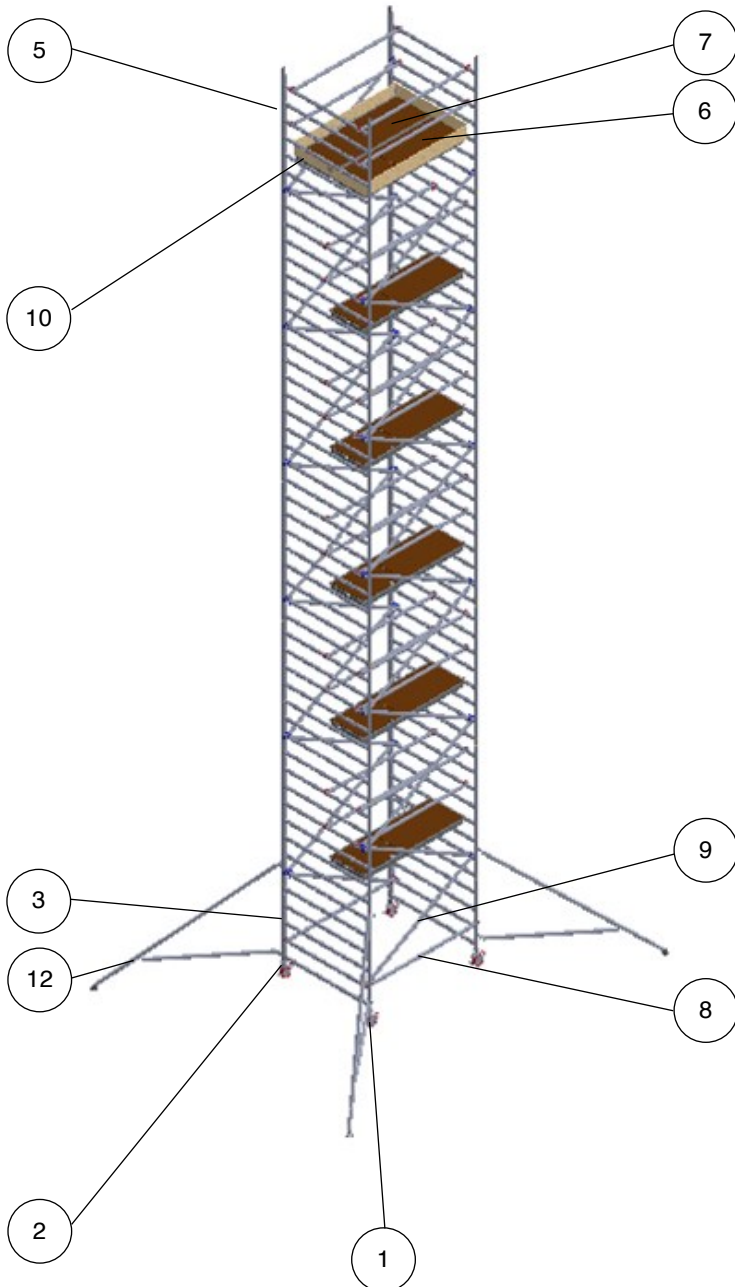

Technical information:

| | |
|---|--------------------|
| Base Dimensions: | (L)1.8m X (W)1.45m |
| Maximum Platform Height (ph): | 12.2m |
| Maximum Working Height (wh): | 14.2m |
| Maximum Working Load Per Platform: | 275kg |
| Maximum Working Load Per Tower: (including tower weight) | 950kg |
| Weight: | 357.2kg |